

# **Alfamacchine**

Innovation for Framing

EN

## **INSTRUCTION MANUAL**



**U200P**  
*Semi-Auto/Pneumatic Underpinner*

Name	<b>FRAME ASSEMBLING MACHINE</b>
Function	<b>ASSEMBLY OF FRAMES BY INSERTION OF METAL V-NAILS</b>
Model / Type	<b>U200P</b>
Serial number	
Year of manufacture	
Manual Revision	<b>02</b>

**PLEASE RETAIN FOR FUTURE REFERENCE**

TRANSLATION OF THE ORIGINAL INSTRUCTIONS (Keep for future reference)



Alfamacchine S.r.l.  
Via Curie M. e P., 3  
47122 Forlì - Italy

## DICHIARAZIONE DI CONFORMITA' CE CE CONFORMITY DECLARATION

Il Fabbricante / the Manufacturer **Alfamacchine S.r.l.**  
con sede legale in / Address **Via Curie Marie e Pierre, 3 47122 Forlì - Italy**

DICHIARA, / Hereby DECLARES,  
sotto la propria responsabilità, under its sole responsibility,  
che la macchina: that the machine:

Denominazione / Product Name : ASSEMBLATRICE PER CORNICI  
Funzione / Purpose : ASSEMBLAGGIO ASTE IN LEGNO-MATERIALE SINTETICO-MDF TRAMITE GRAFFE METALLICHE TIPO "V"  
Modello / Model Name : **U200P**  
Tipo / Type : PNEUMATICA  
Numero di Serie / Serial Number :

E' CONFORME ALLE DISPOSIZIONI PREVISTE DALLE DIRETTIVE:  
COMPLIES WITH THE BELOW MENTIONED STANDARDS AND DIRECTIVES:

- 2006/42/CE, Direttiva Macchine

poiché rispetta tutti i requisiti essenziali di sicurezza e sanitari che le concernono.  
because it complies with all the essential safety health which affect.

Fascicolo Tecnico costituito presso : ALFAMACCHINE S.R.L.

Forlì ,

\_\_\_\_\_  
Data / Issued Date :

\_\_\_\_\_  
Firma il Legale rappresentante / Signature of representative

# EN TRANSLATION OF THE ORIGINAL INSTRUCTIONS

## Contents

<b>1. INTRODUCTION TO USE</b>	<b>4</b>
1.1. HOW TO CONSULT THIS MANUAL AND THE SYMBOLS ADOPTED	4
1.3. TYPE OF USE AND CONTRAINDICATIONS	5
1.4. TECHNICAL CHARACTERISTICS	8
1.5. PRODUCTS PROCESSED - HANDLED OR GENERATED	9
1.6. EMISSION OF AIRBORNE NOISE	9
1.7. RESIDUAL RISKS - GENERAL INFORMATION	9
1.8. RESIDUAL RISKS	10
1.9. DESCRIPTION OF SAFETY FUNCTIONS	11
1.10. MACHINE DESCRIPTION	12
1.11. MAIN MACHINE COMPONENTS	12
<b>2. INSTALLATION</b>	<b>16</b>
2.1. STORAGE	16
2.2. CHECKS ON RECEPTION	16
2.3. TRANSPORT, LIFTING AND HANDLING	17
2.4. LIFTING AND HANDLING	17
2.5. REMOVING THE PACKAGING	18
<b>3. PRELIMINARY PREPARATION AND ADJUSTMENT PROCEDURES</b>	<b>19</b>
3.1. PUTTING THE MACHINE INTO SERVICE	19
3.2. POSITIONING (IF THE OPTIONAL STAND HAS BEEN PURCHASED)	19
3.3. ASSEMBLY OF SEPARATELY SHIPPED UNITS	20
<b>4. INITIAL START-UP AND USE OF THE MACHINE</b>	<b>21</b>
4.1. COMPRESSED AIR SUPPLY	21
4.2. WORKSTATIONS AND OPERATORS' TASKS	23
4.3. CHECKS, ADJUSTMENTS AND START-UP	24
4.4. START-UP	24
4.5. PRELIMINARY PROCEDURES	35
4.6. WORKING CYCLE	35
<b>5. MAINTENANCE, TROUBLESHOOTING, AND CLEANING</b>	<b>37</b>
5.1. MAINTENANCE TECHNICIAN REQUIREMENTS	37
5.2. WORK STATIONS AND MAINTENANCE TECHNICIAN DUTIES	37
5.3. MAINTENANCE INSTRUCTIONS DANGER – WARNING	37
5.4. GENERAL WARNINGS	37
5.5. ISOLATION FROM EXTERNAL ENERGY SOURCES	37
5.6. ROUTINE MAINTENANCE	37
5.7. TASKS THAT CAN BE PERFORMED BY THE OPERATOR	38
5.8. TASKS THAT CAN BE PERFORMED ONLY BY MAINTENANCE TECHNICIANS	39
5.9. CLEANING	42
5.10. LUBRICATION	44
<b>6. TROUBLESHOOTING - RELEASING JAMMED MOVING PARTS</b>	<b>45</b>
<b>7. REINSTALLATION AND REUSE</b>	<b>47</b>
<b>8. EXTINGUISHING MEDIA</b>	<b>47</b>
<b>9. SCRAPPING AND DISPOSAL</b>	<b>47</b>
DANGER - WARNING	47
9.1. SCRAPPING	47
9.2. DISPOSAL	48
<b>TABLE 1 - MACHINE ASSEMBLY</b>	<b>49</b>
<b>TABLE 2 - INSTALLING THE HEAD UNIT</b>	<b>48</b>
<b>TABLE 3 - VERTICAL CLAMPING UNIT</b>	<b>49</b>
<b>TABLE 4 - PNEUMATIC COMPONENTS</b>	<b>50</b>
<b>TABLE 5 – CE PROTECTIVE EQUIPMENT</b>	<b>51</b>
<b>TABLE 6 – STAND (OPTIONAL)</b>	<b>52</b>
<b>TABLE 7 - PNEUMATIC CIRCUIT DIAGRAM</b>	<b>53</b>

 **DANGER - WARNING**  
**BEFORE USING THE MACHINE PLEASE READ THIS MANUAL CAREFULLY SO THAT YOU BECOME FAMILIAR WITH THE MACHINE, ITS ENVISAGED USE AND ANY RISKS ASSOCIATED WITH IT.**

Keep the Use and Maintenance Manual in good condition: Remember, it is an integral part of the machine. Always refer to the manual to get best machine performance in maximum safety while performing the operations described therein. This manual must be kept in an easily accessible place, near the machine, at all times so that it can be consulted whenever necessary.

 **DANGER - WARNING**  
**USE THE MACHINE SOLELY AND EXCLUSIVELY FOR THE USES INDICATED AND IN ACCORDANCE WITH THE RECOMMENDATIONS PROVIDED IN THIS MANUAL. NEVER TAMPER WITH IT, FORCE IT OR USE IT IN ANY INAPPROPRIATE MANNER.**

 **NOTE:** *Certain images are purely illustrative and are not binding. Such illustrations may not reflect the current condition of the machine, due to intervening upgrades and modifications.*

## 1. INTRODUCTION TO USE

### 1.1. HOW TO CONSULT THIS MANUAL AND THE SYMBOLS ADOPTED



Please pay particular attention to the words "DANGER – WARNING", "DANGER – CAUTION" and "NOTE" as used in this manual. To draw the user's attention to certain information and provide warning messages, the operations described in this manual are accompanied by symbols and notes to highlight the presence of any hazards and indicate the safe use of the equipment. These symbols and notes belong to various categories, as indicated below:

 **DANGER - WARNING: IMPORTANT INFORMATION CONCERNING GENERAL SAFETY.**

 **DANGER-CAUTION: highlights situations where careful and sensible actions are essential.**

 **NOTES:** *information of a technical nature.*

### 1.2. WARNING - SAFETY ALERT DECALS (see figure)

Decal	Description
	Wear protective goggles.
	Wear protective gloves.
	Wear safety footwear
	Wear ear defenders
	Risk of impact against obstacles: affixed on the corners of the guards.

<p><b>ATTENZIONE !</b> <b>PER LA VS. SICUREZZA</b> DISINSERIRE L'EROGAZIONE DELL'ARIA PRIMA DI CAMBIARE LA TESTINA PER GRAFFE O ESEGUIRE LAVORI DI MANUTENZIONE SULLA MACCHINA</p>	<p>Safety warning on machine use</p>
<p><b>ATTENZIONE</b> <b>TENERE LONTANO LE DITA</b></p>	<p>Wear protective gloves.</p>
<p>ALFAMACCHINE S.r.l. Via Marie Curie e Pierre, 3 47100 Forlì (FC)</p> <p><b>CE</b></p> <p>DENOMINAZIONE <input type="text"/></p> <p>NUMERO DI SERIE <input type="text"/></p> <p>MODELLO <input type="text"/></p> <p>TIPO <input type="text"/></p> <p>PESO <input type="text"/> kg</p> <p>PRES LAVORO <input type="text"/> bar</p>	<p>EC dataplate</p>



### 1.3. TYPE OF USE AND CONTRAINDICATIONS.

#### GENERAL WARNINGS

The operator must read all the information in this manual carefully, paying special attention to the safety precautions listed in this chapter.

It is also essential for the Operator to abide by the following warnings:

- Always keep the machine and work area clean and tidy.
- Arrange suitable containers for storing the workpieces to be processed and those that have already been completed.
- NEVER use the machine when not in good psycho-physiological condition.
- Always wear suitable workwear to avoid any hindrances and/or hazardous entanglement in machine parts.
- Personnel must be authorized and trained beforehand on machine use by Alfamacchine technicians.
- Wear all necessary personal protective equipment: safety footwear, gloves and protective glasses
- The operator must wear personal protective equipment indicated in the Instruction Manual, in accordance with the operations to carry out.
- Never remove or alter the dataplates affixed to the machine by the Manufacturer.
- Keep fingers well away from the operating area.
- Keep feet away from the pedal during machine adjustment operations.

#### PERMITTED USE

The machine described herein is designed to be run by 1 operator suitably trained and instructed with regard to residual risks. The operator must have the same skills, in terms of safety, as the maintenance technicians and adequate professional competence.

During its PERMITTED AND REASONABLY PREDICTABLE USE, the machine may be used exclusively:

- to work with wooden mouldings of various hardness, with multiple surface finishes, for the purpose of making frames for pictures, mirrors, display cases, cupboard doors etc.) in accordance with the characteristics described in the heading "Products Processed - Handled or Generated". Use of the machine to perform processes other than those described in this manual is to be considered improper and therefore strictly prohibited.
- with the products (and materials) described and having the dimensions specified in the heading "TECHNICAL CHARACTERISTICS".

It is also compulsory:

- for the machine to be used by one operator only who has received adequate training/information concerning machine operations, performance and any hazards associated with its use.
- to ensure no exposed persons are present in the machine's operating area before proceeding with any operations whatsoever.
- to check the perfect condition of all the safety devices before starting to work with the machine.
- to ensure, when the machine is placed on the factory floor where it is to be used, that it is installed on a level, smooth and perfectly horizontal surface. The floor must have an adequate load bearing capacity to support the weight of the machine.
- to check, prior to starting work with the machine, the conditions of ambient lighting and ensure there are no areas of shadow, glare, or potentially hazardous strobe effects.
- to disconnect, prior to starting any work on the machine, the main compressed air supplies, to safely discharge any residual energy in the machine circuits, and wait for all parts at high temperatures to cool down adequately.

**IMPROPER USE DANGER - WARNING****THE MACHINE MUST NOT BE USED IN A PROHIBITED MANNER. SPECIFICALLY:**

- it cannot be operated with parameters different to those shown in the “TECHNICAL CHARACTERISTICS” table or with products and/or materials with different characteristics to those previously described in the heading “TECHNICAL CHARACTERISTICS”.
- all uses of the machine other than those described in this manual are construed as improper and as such the manufacturer declines all liability.
- the user is responsible for any damage resulting from failure to observe the operating conditions agreed at the time of technical specification and order confirmation.

**FORBIDDEN USE**** DANGER – WARNING  
FURTHERMORE IT IS PROHIBITED TO USE THE MACHINE IN AN INCORRECT MANNER, IN PARTICULAR:**

- never leave the loaded machine unattended,
- never use flammable, corrosive or toxic substances to clean the machine,
- never allow unauthorized personnel to use the machine,
- never smoke or use open flame equipment or handle incandescent material, unless adequate safety measures have been adopted,
- never activate or adjust the control and locking devices, such as knobs or similar devices, during machine operation or when not authorized to do so,
- never hang objects or weights on the machine,
- never use the machine with the safety guards open, incorrectly fastened, or removed,
- never use the machine with the safety microswitches and interlocking safety devices inhibited and, in general, with any safety and/or protective device (mechanical) deactivated and/or non-functional
- •never partially or totally by-pass, remove, modify or in any way render ineffective the guards, safety devices and warning signs
- use of the machine is forbidden when the user has not adopted all the necessary measures to eliminate the residual risks as indicated in this instruction manual,
- never use the machine for operations other than those explicitly indicated in this instruction manual,
- never use the machine in environments for which it has not been designed unless all necessary safety measures have been adopted beforehand,
- the machine must not be used by untrained personnel
- foodstuffs must not be brought into contact with the machine,
- it is prohibited to activate the control devices for machine movements without first checking and ascertaining the absence of persons in the danger areas subject to machine movements,
- it is prohibited to enter the operating / danger zone of the machine during control of the machine’s moving parts,
- it is prohibited to enter the machine working area with any part of the body, hands and arms included, before hazardous moving elements have come to a complete standstill.
- it is prohibited for the machine operator and maintenance technician to enter the danger zones to perform cleaning, lubrication, maintenance operations etc. without having first set the power cut-off switches to “ZERO” and padlocked them in this position,
- the machine must not be used in critical conditions of stability, i.e.:
  - when placed on a support surface which is not perfectly horizontal and smooth, or does not have an inadequate load capacity as indicated in this manual,
  - outdoors or worksites with open windows and doors,
- the following are strictly prohibited:
  - processing of materials and products that are not expressly indicated in the present manual,
  - processing of metal materials made of aluminium, lightweight alloys, and steel and its alloys.

** DANGER – CAUTION  
*The manufacturer cannot be held liable for any faults caused by unreasonable, improper and/or incorrect use of the machine.***

The user is anyway responsible for all damage deriving from failure to comply with the specified terms of use. For any further information always consult the manufacturer’s engineering department.

The user is always responsible for providing suitable personal protective equipment to machine operators and for informing them on the permissible uses of the machine.

**PERSONNEL AUTHORIZED TO USE THE MACHINE**

This machine has been designed and manufactured to be used by qualified personnel with adequate training, experience and skills in accordance with the characteristics described below:

**Operators / Apprentices:**

- may be male or female,
- must be aged 14 or over,
- must have full use of both hands,
- must have no physical or mental disabilities,
- must know and fully understand the contents of the user manual.

**PERMITTED AMBIENT CONDITIONS AND OPERATING LIMITS****ANGER - WARNING**

**THIS MACHINE IS NOT SUITABLE FOR USE IN A POTENTIALLY EXPLOSIVE ATMOSPHERE. THEREFORE IT IS PROHIBITED TO INSTALL OR USE IT IN ANY SUCH ENVIRONMENT.**

**SERVICE CONDITIONS**

SERVICE CONDITION	USER LIMITS
Installation type	Indoors
Floor conditions	Horizontal and smooth: irregularity and gradient tolerance within 2%
Supporting surface characteristics	Flooring in compliance with health and safety requirements in the workplace in accordance with all applicable legislation
Maximum ambient air temperature	+40°C / 104 °F
Minimum ambient air temperature	5°C/ 104 °F (if the electrical equipment as a protection rating of at least IP54) 0°C/32°F (if the electrical equipment has a protection rating lower than IP54)
Ambient working temperature	+5 °C < T < +45 °C / 113 °F
Transport and storage temperature	between -25°C / -13 °F and +55°C / 131°F (temperatures of up to +70°C/158 °F are admissible for periods of less than 24 h)
Maximum altitude above sea level	1000m
Minimum required light intensity	600 lux
Relative humidity	100% at +25°C/ 77°F(if the electrical equipment is rated at least IP54) The relative humidity must not exceed 50% at +40°C / 104°F or 90% at +20°C / 68 °F (if the electrical equipment is rated lower than IP54)
Equipment for machine designed for indoor installations	
Machine NOT suitable for operation in contaminated atmospheres: for example, dusts, acids, corrosive gases, salt or similar contaminants.	
Machine <b>NOT SUITABLE</b> for operating in potentially explosive atmospheres classified as zone 0, zone 1 or zone 2.	
Machine <b>NOT</b> suitable for operation in environments subject to the presence of ionizing and non-ionizing radiation: for example, microwaves, UV rays, laser, X-rays, and similar.	
Electrical equipment NOT suitable for installation on machines or for operation in places subject to vibration and impact: otherwise, install equipment well clear of source of vibration and impact and fit antivibration supports	
Pollution class of electrical equipment equivalent to 3 (THREE)	
Installation environment equivalent to two (2)	
Can be utilised in residential, commercial, of light industrial zones thanks to compliance with standard EN 61000- 6- 1 Intended for direct/exclusive service of industrial process equipment	



**SERVICE CONDITION USER LIMITS**

Unforeseen special or supplementary prescriptions may apply to machines intended for:

- outdoors use;
- handling potentially explosive materials;
- use in potentially explosive and/or flammable atmospheres;
- use involving specific risks in the processing of specific materials;
- use in mines;
- use in refrigeration plants;
- use at high temperatures;
- use in corrosive environments;
- use in strong magnetic fields;
- use in radioactive conditions;
- use for loads the nature of which could lead to hazardous situations (for example, molten metal, acids/bases, particularly fragile loads, explosives),
- use on ships and areas affected by earthquakes;
- food-contact use;
- use in public areas;
- use in aircraft ground support.

**1.4. TECHNICAL CHARACTERISTICS**

**Machine characteristics**

Working bench dimensions (WxL) .....	330x450mm -13"x 18"
Maximum machine height .....	450mm - 18"
Machine weight .....	32kg - 83lbs
V-nail magazine capacity .....	220pz
Max. quantity of V-nails inserted per position .....	9pz
V-Nail insertion positions .....	Multiple
Max. distance between nails .....	160mm
Min / max moulding width .....	6 / 120 mm - 1/4" – 5"1/8
Min / max moulding height .....	6 / 80 mm - 1/4" – 3"1/4

**V-nail characteristics**

Height .....	7-10-12 mm
Optional head heights .....	3-5-15 mm

**Compressed air supply**

Maximum permitted inlet pressure .....	8bar
Operating pressure .....	2 ... 8 bar
Specific air consumption .....	3 NI

**V-nail characteristics**

V-nail type	Height mm
H3	3mm (optional)
H5	5mm
H7	7mm
H10	10mm
H12	12mm
H15	15mm



Material	Recommended sharpness
Soft wood and plastic	SW transparent stick
Medium wood	MW brown stick
Hard wood	HW green stick
Very Hard Wood and MDF	HS red stick



### 1.5. PRODUCTS PROCESSED - HANDLED OR GENERATED

The products handled by the machine described herein must be made up of wooden mouldings of various hardness, with multiple surface finishes, for the purpose of making frames for pictures, mirrors, display cases, cupboard doors etc..

The main technical characteristics of the products handled by the machine described herein are provided below.

#### DESCRIPTION OF PRODUCTS HANDLED CHARACTERISTICS

Minimum/maximum profile height	6 - 80 mm
Minimum/maximum profile width	6 - 120 mm

### 1.6. EMISSION OF AIRBORNE NOISE



*NOTE – The manufacturer declares, under his own responsibility, that the machine produces a continuous equivalent A-weighted sound pressure level of 72 dB.*



#### **DANGER - WARNING:**

**TO AVOID THE DANGER OF HEARING DAMAGE CAUSED BY SHRILL OR INSISTENT NOISE, THE MACHINE OPERATOR AND MAINTENANCE TECHNICIAN MUST ALWAYS USE APPROPRIATE HEARING PROTECTION, SUCH AS HEARING DEFENDERS OR EARPLUGS.**

### 1.7. RESIDUAL RISKS - GENERAL INFORMATION

This manual contains a list and description of the residual risks that could not be eliminated in the design stage and that therefore remain present on the machine.

For each risk, suitable instructions or prescriptions are given which the user must observe in order to avoid hazards affecting the machine operator, maintenance technicians, any exposed persons and the machine itself.

## 1.8. RESIDUAL RISKS

For each risk, suitable instructions or prescriptions are given which the user must observe in order to avoid hazards affecting the machine operator, maintenance technicians, any exposed persons and the machine itself.

### Residual risk of finger crushing

During the normal operating cycle and during maintenance, Operators are exposed to certain residual risks which, due to the nature of the operations could not be completely eliminated.

- Finger crushing hazard in the operating area of the vertical clamp (A).

Furthermore, it is to be pointed out that said finger crushing risks are present near each mobile element installed over the machine's working bench.

Consequently the operator and maintenance technician, as well as observing the instructions provided in this manual, must never place their fingers or any other part of the body in the zone indicated.

Furthermore, workers must never wear rings, wrist watches, jewellery, torn clothing, scarves, ties or any other loose clothing or personal accessories that may constitute a risk. Make sure sleeves fit snugly around wrists and keep long hair tied back.

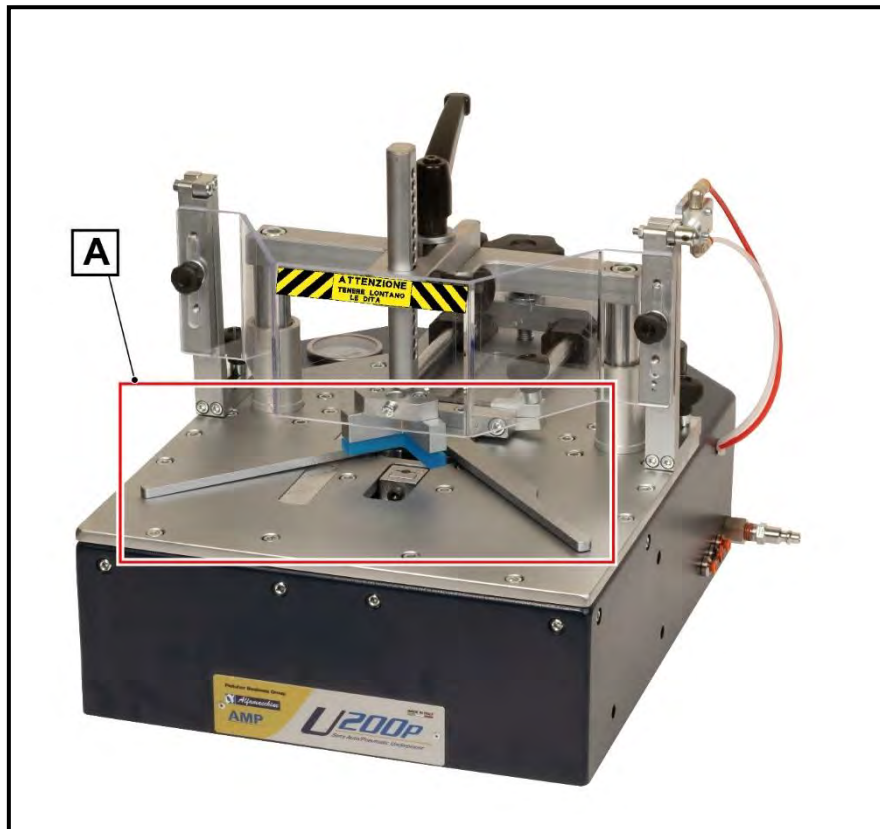

### Residual risk due to the combustibility of the substances used in the machine and the products handled by the same

To avoid the hazards resulting from:

- the ignition of substances used in the machine,
- residual risks associated with possible outbreaks of fire;

the employer, in addition to training and adequately informing the machine operator and maintenance technician on such risks, must provide permanent fire protection systems in the vicinity of the machine control station. Said systems must be suitable for the types of material which could catch fire.

### **PPE to be used:**



Protective gloves



Safety footwear



Safety clothing



Ear defenders

### Residual risk due to noise

As demonstrated by experimental tests, the machine produces a continuous equivalent A-weighted sound pressure level of 70 dB. To avoid the risk of hearing damage caused by shrill or insistent noise during machine use, in addition to being adequately informed and trained, the operator and maintenance technician must always use appropriate hearing protection, such as hearing defenders, earplugs or similar personal protection equipment to safeguard hearing.

### **Residual risk caused by piloting the valves**

There is a residual risk for the maintenance technician, when the safety guards are open and the valve pilots are activated, **in order to check (during troubleshooting procedures) the operation of the pneumatically operated mobile elements, when energy remains accumulated in the actuator cylinders.**

Consequently, when the aforementioned activities are performed, the maintenance technician must make sure that no exposed persons are found near the pneumatically controlled mobile elements and in any case said mobile elements must only be activated if strictly necessary for pinpointing operating faults.

### **Residual risk due to the presence of accumulated energy inside the pneumatic actuator cylinders**

There is a residual risk for the maintenance technician when the machine is isolated from the compressed air network, **due to the presence of accumulated energy inside the actuator cylinders**, when mobile guards are open caused by the presence of closed-centre valves and/or tanks which remain pressurized.

Please note that said piping is duly identified and indicated to distinguish it from all other piping installed on the machine.

Consequently, before carrying out any work on the aforementioned cylinders, in accordance with the instructions given in the actuator manuals, the maintenance technician must neutralise the accumulated energy working in compliance with the safety regulations applicable to maintenance personnel, such as, for example, manual activation of the special tool for the piloting valves used to discharge stored energy.

Under no circumstances must the piping be disconnected if they still hold residual pressure.

## **1.9. DESCRIPTION OF SAFETY FUNCTIONS**

### **Protective devices installed on the machine**

 **DANGER - WARNING**  
**IT IS STRICTLY PROHIBITED TO REMOVE THE PROTECTIONS AND SAFETY DEVICES EXCEPT WHEN STRICTLY NECESSARY FOR THE PURPOSE OF CARRYING OUT MAINTENANCE WORK.**

 **Periodically check the efficiency of the safety devices.**

When such safeguards and safety devices need to be removed all necessary measures must be adopted to highlight this situation immediately and minimise any possible associated hazards.

The safeguards and safety devices must be refitted as soon as the reasons for their temporary removal are no longer applicable.

Each operating unit of the machine is protected by a guard, which may also be a fixed guard designed to prevent access to dangerous parts, except:

- in the upper part of the working bench to perform adjustments, tooling, parts replacement, etc.
- in the lower part of the working bench to perform adjustments, tooling, parts replacement, etc.

## 1.10. MACHINE DESCRIPTION

The U200P frame assembling machine has been designed to assemble every kind of frame.

The U200P, with its simple and easy-to-use construction, can execute precise joins of any type of moulding using special steel V-nails. It can operate with normal V-nails, reinforced V-nails for very hard wood and special ALFAGRAF V-nails with "pulling power" of various heights.

## 1.11. MAIN MACHINE COMPONENTS

The equipment listed below refers to standard machines. Consequently, any special supplies may have some different components to those listed. After removing the machine from the packaging, make sure the following accessories are present:

- 1 head for 7-mm V-nails;
- 1 head for 10-mm V-nails;
- 1 Head for 12-mm V-nails;
- 1 Mechanical stopper holder;
- 1 Magnetic support;
- 1 interchangeable stopper - soft (light blue);
- 1 Interchangeable stopper - medium (yellow);
- 1 Interchangeable stopper - hard (black);
- 1 Round magnetic felt stopper;
- 1 Wrench (5-mm) for changing heads;
- 1 Wrench (6-mm) for machine assembly;
- 1 Rod with magnets (pencil magnet) for V-nail removal;
- 1 Fixed 90° fence;
- Single clamp;
- Stand (optional);
- Instruction manual

The main components that make up the machine are:

### •Working bench

The working bench is the surface on which manual operations take place to move, clamp and join the frame mouldings, also incorporating all the operator controls.

It is made up of the following main parts:

- (A) Vertical moulding clamp unit
- (B) Alignment guides unit
- (C) Nail firing unit and magazine
- (D) Clamping unit air pressure adjustment
- (E) Alignment guide travel stop adjustment unit

### Vertical clamp unit

This unit is designed to immobilize the mouldings on the working bench and counteract the V-nailing force.

Its position ensures that the stopper is aligned with the firing head and is therefore in line with the direction of V-nail insertion. It is important that the air pressure applied to the vertical clamp provides thrust which is always higher than the thrust of the V-nails, if this is not the case, V-nail insertion could result in the mouldings being lifted up, resulting in incomplete insertion of the V-nail and a poor quality join.

The unit is made up of a mechanical or magnetic stopper holder (P) to which the interchangeable rubber stoppers of varying hardness are applied, located at the bottom of a punched column (N) which can be positioned at various heights depending on the size of the frame.

The assembly is fastened to two sturdy columns (S) the movement of which is controlled by pneumatic actuators. The punched column is installed on a support (R) which makes it possible to carry out horizontal adjustment of the stopper along the line of assembly.

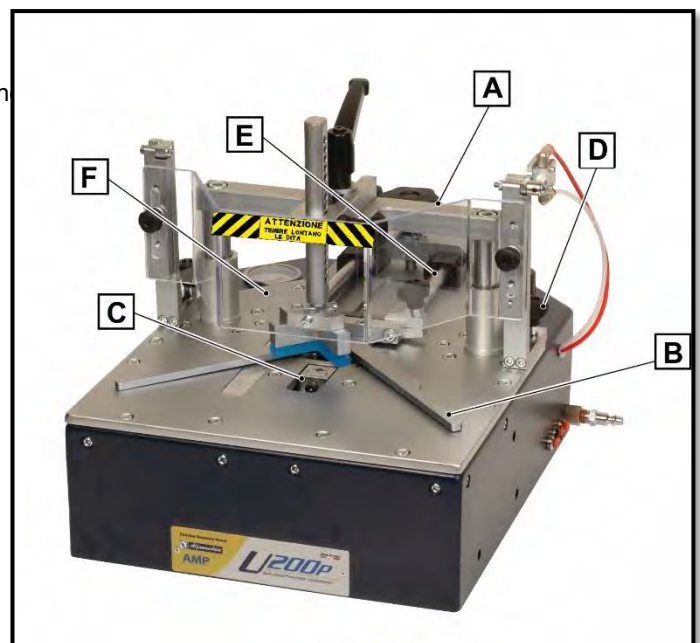

The vertical stopper unit is made up of the following main parts:

- (N) punched rod which allows the operator to position the stopper at various heights based on the various frame profiles
- (O) Screw for fastening and for rapid changeover of the mechanical stopper holder or the magnetic support;
- (P) Stopper holder, which may be mechanical or magnetic depending on the type of accessories used.
- (Q) Click knob for locking the column.
- (R) Drilled rod support arm.
- (S) Piston stem vertically activated by the pneumatic actuator.

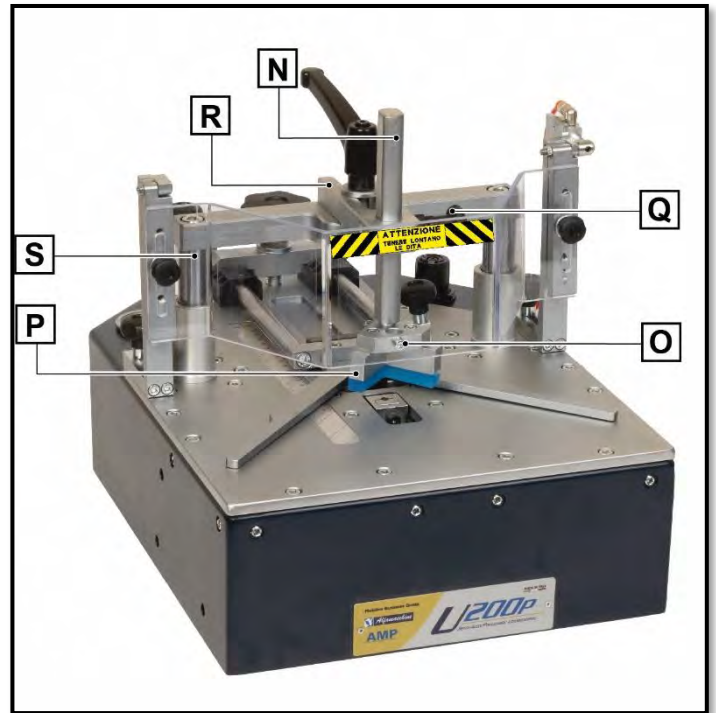

**Stoppers available on request:**

- F) Mechanical stopper holder;
- E) Interchangeable stopper - soft (blue);
- E) Interchangeable stopper - medium (yellow);
- E) Interchangeable stopper - hard (black);
- I) Round magnetic felt stopper;
- G) Corner magnetic stopper holder;
- H) Magnetic support

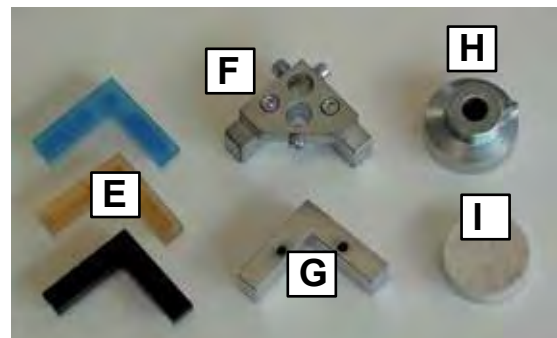

### V-nail firing unit and magazine

In the U200P machine, the magazine (E) can hold V-nails of different heights but only one V-nail height can be used at a time, depending on the nailing head installed.

When the size of the V-nails is changed the nailing head must also be switched over to match the V-nails used.

The V-nails are held in position by the V-nail pusher device (F).

Head and L-block support are designed to guide the V-nails during the thrust action of the hammer and their insertion into the overlying mouldings.

The magazine is in turn brought up against the L-block support and by means of a V-nail pusher supplies and aligns the V-nails against the guide each time the hammer is activated. The hammer is activated by a pneumatic cylinder which is controlled by the pneumatic pedal.

Perfect mechanical alignment of these parts ensures precise insertion, single or multiple, of the V-nails in the mouldings to be joined, in the quantity and with the spacing required.

- (A) Screw for fastening the head.
- (B) Hammer.
- (C) Head of different heights.
- (D) L-block support
- (E) V-nail pusher which keeps the V-nails at a constant pressure up against the firing unit.
- (F) V-nail magazine

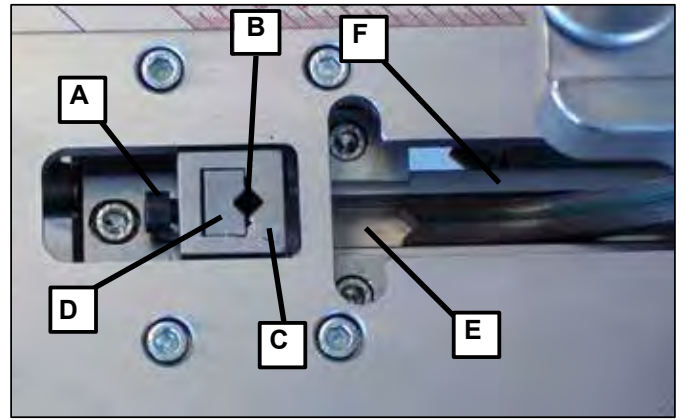

### Pneumatic pedal hook-up

Before connecting the machine to the pneumatic system, you must first connect the control pedal.

The three air lines which are connected to the pedal assembly must be inserted in the three connectors located on the right-hand side of the machine in the following order:

- 1) RED line in the connector on the outer side (1) (pedal supply).
- 2) BLACK line on middle connector (2) (vertical clamping).
- 3) TRANSPARENT line on the operator side connector (hammer).

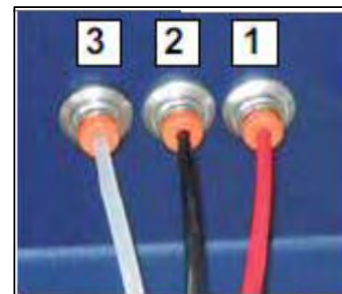

### Alignment guides unit

The alignment fences unit, positioned on the working bench, can slide along the assembly line of the firing unit and its position is adjusted by the operator.

Fixed fences for 120° and 135° corners may also be installed in the fence support (A) for making frames with 6 and 8 sides respectively (available as optional accessories).

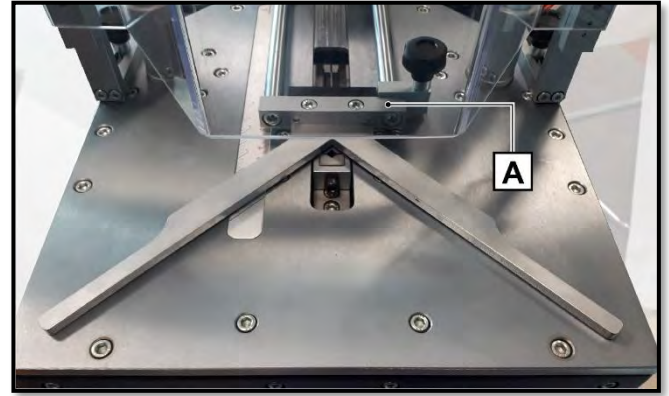

### Two-knob fence (optional)

The fixed fence can be replaced with the two-knob model (C) which allows the user to adjust the tilt of the moulding stop in relation to the work bench.

Mouldings may have a slanting edge which would make the action of the horizontal clamp ineffective. The two-knob fence is designed to include tilt adjustment of the surface against which the moulding rests to improve stability.

The two-knob fence can be used to improve clamping of the mouldings during assembly.

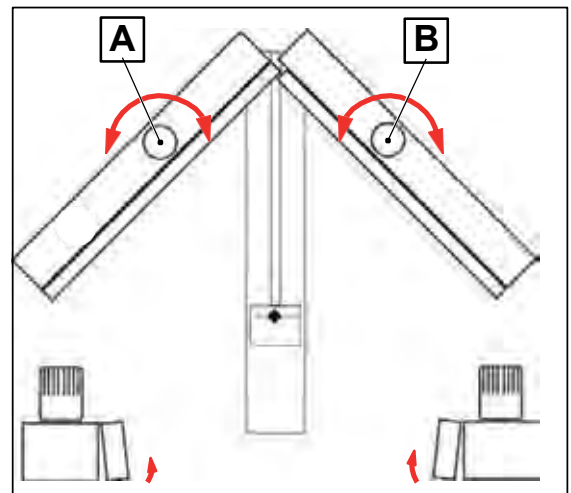
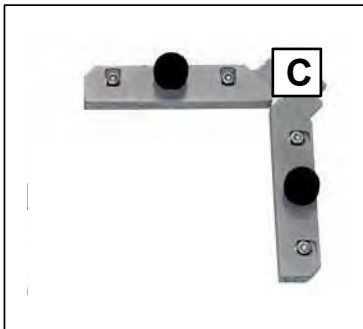

## 2. INSTALLATION

### 2.1. STORAGE

The machine, intended for indoor installation must be stored, if necessary, in well ventilated storage facilities and protected from dust. The delivered elements must remain in their original packing until the time of final installation. All parts of the machine subject to the risk of oxidation are protected with grease and protective sprays at the time of dispatch to prevent oxidation caused by weather conditions.

In the case of prolonged inactivity the machine must be stored with all necessary precautions taken based on the location and expected storage times:

1. Store the machine in an enclosed place.
2. Protect the machine from impact and stress.
3. Protect the machine from humidity and excessive temperature differences (refer to the table below).
4. Do not allow corrosive substances to come into contact with the machine.
5. Check that the pack has not been damaged and that it is perfectly dry.
6. Specifically, if the machine is inside a shipping container, the storage area must be covered and protected against direct weather including rain, snow and hail, and it must be accessible exclusively to authorized personnel.

The machine is protected in such a way as to withstand the temperatures, humidity and vibration levels typically associated with transport and storage.

Ambient temperature	-25 / +40 °C	Avoid places where there may be unexpected changes in temperature that could lead to the formation of condensate or freezing.
Storage temperature	-25 / +55 °C 0 / +55 °C	
Relative humidity	100% at +25°C Lower than 50% at +40°C Lower than 90% at +20°C	
Vibrations	5.9 m/s <sup>2</sup> (0.6G) or higher	
Atmospheric pressure	900 mbar or greater	

Storage temperature is construed as a short-term value, e.g. during transportation. Condensation or freezing normally occurs in sites subject to significant temperature excursions. Even if relative humidity in such conditions falls within the values shown in the table, locations subject to significant temperature changes should be avoided.

### 2.2. CHECKS ON RECEPTION



#### NOTES

*It is essential to check the packs at the time of arrival and in the precise moment in which they are received. The check is performed in two stages for each pack received to avoid misunderstandings with the shipping agent.*

#### Administrative check

1. Crate number and number of packs.
2. Weight and size
3. Correspondence of information on shipping document with the material effectively delivered (description, serial number, etc.).  
The technical data given on the machine identification plate must correspond with the data given in the technical data supplied).
4. Check correspondence between shipping document data and the order.

#### Technical check

1. Condition and intactness of packaging.
2. Check that the packaging shows no signs of visible damage caused during transport and handling operations.

All the above checks must be performed by inspection in the presence of the shipping agent's delivery person. If any damage is noted or the supply is incomplete or incorrect, inform the manufacturer's sales department immediately.



#### NOTES

*In relation to the above prescriptions, the manufacturer informs the user that in compliance with current international and national rulings, goods are always shipped at the risk and responsibility of the purchaser and, unless otherwise stated in writing at the time of the order confirmation, freight travels without insurance cover.*



### 2.3. TRANSPORT, LIFTING AND HANDLING

Dimensions, weight and handling of individual machine parts

#### **BOX DIMENSIONS**

Height (B) = ..... 400 mm (15 3/4")  
 Depth (C) = ..... 400 mm (15 3/4")  
 Width (A) = ..... 600 mm (23 5/8")  
 Weight of machine (including packaging) 35 kg (78lbs)



#### **DANGER – CAUTION**

- The machine must be transported to a position as close to the intended installation site as possible. Said site must be checked beforehand to obtain information about the necessary clearances and dimensions, including the essential space required for installation procedures.
- It is strictly prohibited to lift loads over people. If persons are present in the area, lower the load and ensure everyone moves out of the way.

### 2.4. LIFTING AND HANDLING

The U200P machine is shipped ready for use.

The U200P is supplied **WITHOUT** its stand.

The box dimensions are: (600x400x400mm – AXBXC). (see figure) Transport must be carried out by professionally qualified personnel.

The machine must be transported in such a way as to avoid any damage to its components:

- The machine must be transported in its installation position.
- Before transporting the machine, grease all non-painted parts to avoid the risk of deterioration;
- Based on the type of transport, take care to protect the machine from all possible impact and stress.



*NOTE – The machine must be lifted by TWO operators.*



*NOTE –It is advisable to keep the packaging in case it is needed to store or transport the machine at a later date.*

The machine is moved on a two-wheel trolley.

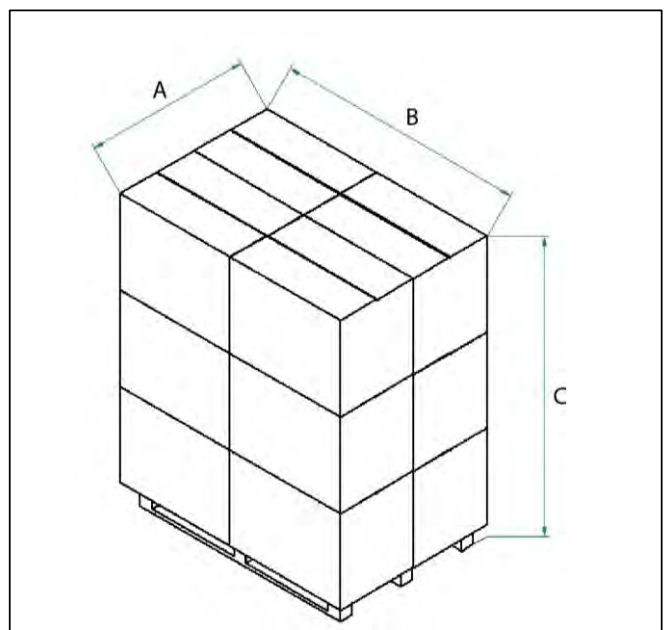
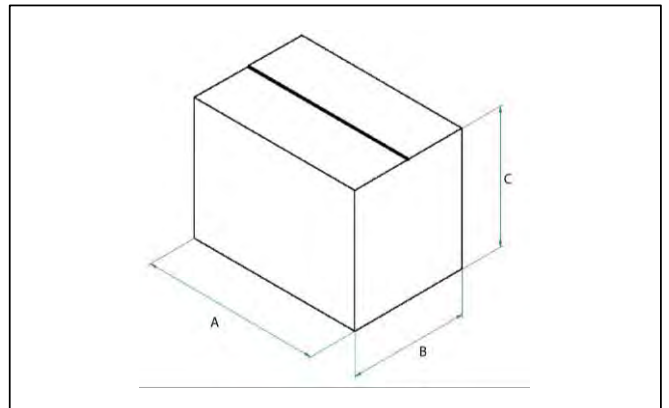

#### **MULTIPLE TRANSPORT AND HANDLING**

The transport of more than one machine can be carried out using a EURO PALLET which can carry up to a maximum of 10 boxes (10 machines)

**Overall dimensions** = (80x120x180mm - AxBxC).

## 2.5. REMOVING THE PACKAGING

### Description of the packaging

The machine may be shipped in a container or on a lorry.

In both cases the same type of packing is envisaged which is suitable for guaranteeing the good condition and proper preservation of the machine during transport up to the time of delivery to the customer.

The machine is shipped packed in a special box and protected against damage by polystyrene inserts.  
Maximum dimensions 660x400x400 (AxBxC).

 **NOTE** –It is advisable to keep the packaging in case it is needed to store or transport the machine at a later date.

When storing the machine, never stack two machines packed on a pallet with shrink wrap.

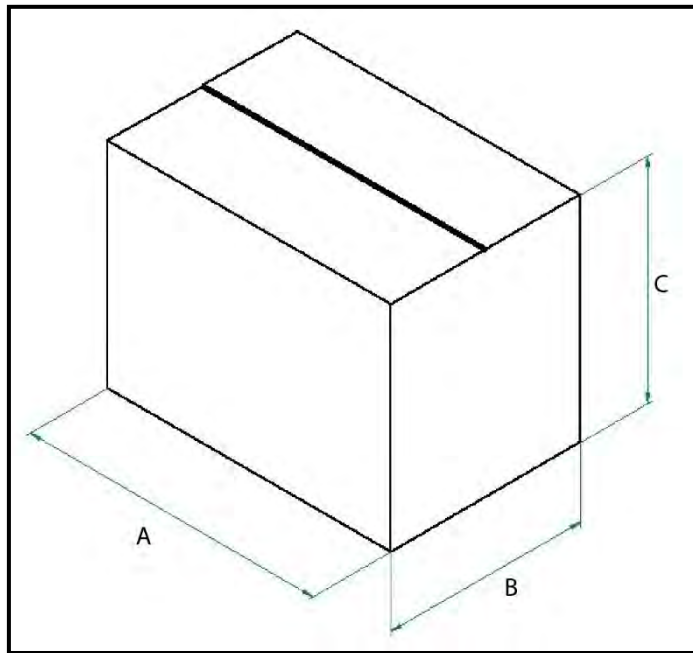

The various packing materials must be disposed of in compliance with the relative legislation in force. Seek advice from the delegated authorities and/or the assistance of specialist companies authorised to dispose of pollutant or recyclable waste products.

 **DANGER – CAUTION**  
**Warning – pollution hazard: do not dispose of the packing material in the environment; retain it for future transport uses or consign it to a recycling company.**  
**Evaluation and management of the packing materials in terms of biological compatibility are the duty and responsibility of the user.**

### 3. PRELIMINARY PREPARATION AND ADJUSTMENT PROCEDURES

#### 3.1. PUTTING THE MACHINE INTO SERVICE

- 1) POSITION THE MACHINE ON THE TABLE OR ANOTHER HORIZONTAL WORKSURFACE
- 2) CONNECT THE PEDAL BY INSERTING THE AIR LINES IN THEIR CONNECTORS ON THE SIDE OF THE MACHINE.
- 3) CONNECT THE COMPRESSED AIR SUPPLY LINE.
- 4) FIT THE VERTICAL CLAMP UNIT.

#### 3.2. POSITIONING (IF THE OPTIONAL STAND HAS BEEN PURCHASED)

##### Suitability of the floor – supporting surface

The machine must be positioned on a solid, reinforced concrete foundation.

The foundations must have an adequate load bearing capacity to support the weight of the machine. The foundations must be designed and created by the employer.

##### Preparation on site

The machine layout is provided as an attachment to this manual. It is complete with the necessary data for positioning on the factory floor.

THE PLACE IN WHICH THE MACHINE IS USED must be clean and free of obstacles (see figure).

TO ALLOW FOR EASY REMOVAL OF THE MACHINE FOR MAINTENANCE it must be positioned in a place having the surface dimensions indicated in the figure.

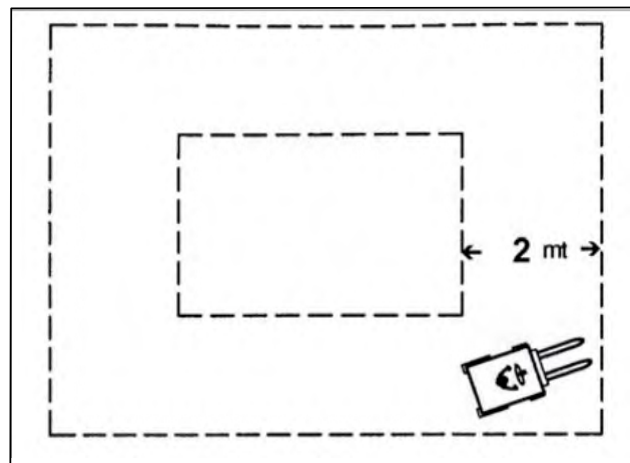

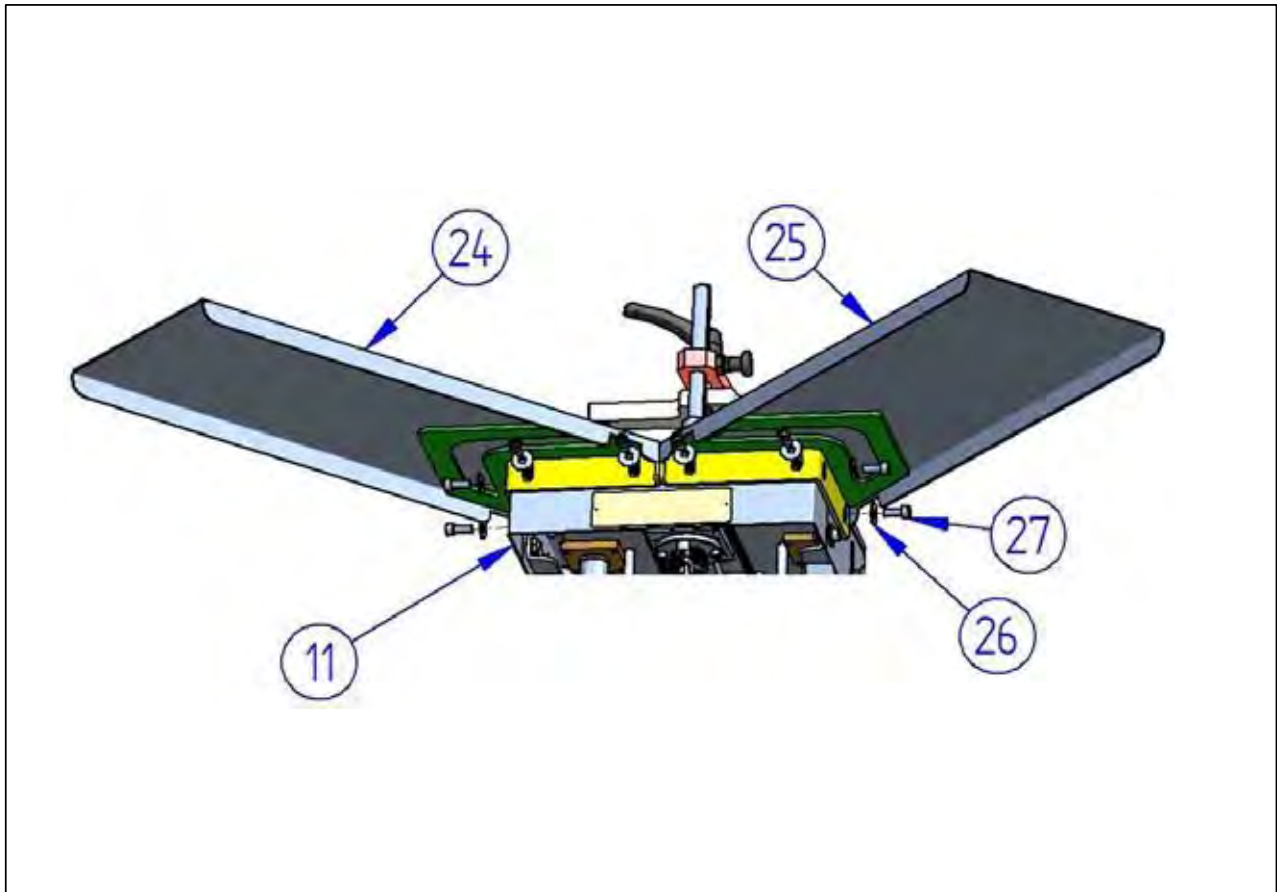

### 3.3. ASSEMBLY OF SEPARATELY SHIPPED UNITS

#### **!** DANGER – CAUTION

*All assembly activities concerning machine units supplied separately, include highly delicate operations which call for significant experience. Consequently they must be carried out exclusively by personnel appointed directly by the manufacturer or authorised by the same and, in any case, under the manufacturer's responsibility. These activities are therefore the sole responsibility of the machine manufacturer's personnel.*

#### **Installation of working bench extensions (optional)**

The working bench extensions are optional and may be requested from the manufacturer.

Their installation requires precise alignment between the working bench and the extensions so that the lower surface of the mouldings rest fully on the entire support surface when the double stopper presses down on the ends of the mouldings.

To install the extensions proceed as follows:

1. Unscrew the grub screws located on the left- and right-hand sides of the machine.
2. Place the right and left extensions alongside the machine accordingly.
3. Insert the fixing screws and align the extensions. Finally, tighten the screws.

## 4. INITIAL START-UP AND USE OF THE MACHINE



### DANGER - WARNING

**THE MACHINE MUST ONLY BE OPERATED BY AUTHORISED AND DULY TRAINED PERSONNEL WITH ADEQUATE TECHNICAL EXPERIENCE.**

**MACHINE OPERATORS MUST BE AWARE OF THE FACT THAT KNOWLEDGE AND IMPLEMENTATION OF THE SAFETY RULES ARE AN INTEGRAL PART OF THEIR WORK.**

**UNQUALIFIED PERSONNEL MUST NOT BE ALLOWED ACCESS TO THE MACHINE'S OPERATING AREA WHILE IT IS IN USE.**

Before switching on the machine, operators should:

- carefully read all the technical documentation
- know which protective equipment and emergency devices are available on the machine, where they are located, and how they work

The partial removal of safety guards and warning signs is forbidden.

Unauthorised use of commercial parts and accessories belonging to safety guards and safety devices can result in malfunctions and the occurrence of hazardous situations for operators.

Before starting the production cycle, the operator must be thoroughly familiar with:

- The position, function and use of all controls.
- The position, function and use of all safety devices.
- The machine's characteristics.
- This manual, and know how to consult it.

The operator must also have been appropriately trained.

### 4.1. COMPRESSED AIR SUPPLY

The compressed air supply must be maintained in compliance with the following technical prescriptions:

- The compressed air supply must be of the type and intensity specified on the first page of the "pneumatic diagram". If excessive pressure values are applied the components will be irreparably damaged.
- taking into account the fact that the machine's pneumatic system is construed as a component of the distribution network, in the context of protection against overpressure, a protection device must be installed coordinated with the machine's pneumatic circuit, in compliance with legislation and the legislative and regulatory provisions in force in the country of installation
- The pneumatic system compressed air supply lines must be routed through the spaces provided by the user and must be adequately protected.
- The compressed air supply line must have a section and characteristics corresponding to the specifications shown on the first page of the "pneumatic diagram". Pipelines of different sections to those specified can alter pressure values and therefore impair correct operation of the machine.

The following units are incorporated in the compressed air inlet point:

#### Standard supply:

- (A) Quick-fit coupler.



#### Pneumatic pedal hook-up

Before connecting the machine to the pneumatic system, you must first connect up the control pedal.

The three air lines which are connected to the pedal assembly must be inserted in the three connectors located on the right-hand side of the machine in the following order:

- 1) RED line on the outer side connector (1) (pedal supply).
- 2) BLACK line on middle connector (2) (vertical clamping).
- 3) TRANSPARENT line on the operator side connector (3) (hammer).

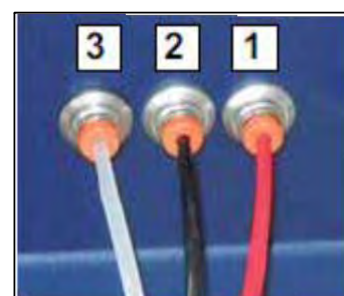

### **User's compressed air production system**

The compressed air production system must be designed, installed and maintained in compliance with the applicable prescriptions indicated in the safety regulations in force.

To high obtain quality compressed air, note that:

- maintenance and operation of the compressors, the auxiliary systems and the primary systems must be in compliance with the manufacturers' instructions and specifications
- the lubricant must comply with the specifications given by the compressor manufacturer;
- the compressor or its suction line must be positioned in an area having the lowest possible level of pollution from vehicle exhausts, fumes exhaustion from industrial processes, etc.
- a filter should be installed on the compressed air line as close as possible to the user point.

#### **Air quality:**

- To obtain the best possible performance and the maximum lifetime of the pneumatic system use compressed air having a dew point between +2°C and + 10°C.
- use a separate air filter, installed as close as possible to the user point. Flush the line with compressed air before connecting it.

For correct use of compressed air, in general terms, consult the following reference standards:

- ISO 8573 – 1, this standard defines the industrial compressed air quality for general use without considering the quality of air at the compressor outlet.
- The compressed air quality level for special applications must be based on the value resulting from a large number of measurements taken during a specific time period and in clearly defined operating conditions.

For the required minimum pressure value, the nominal working pressure and the air consumption expressed as the average value for correct operation of the machine, refer to the heading "TECHNICAL CHARACTERISTICS".

### **Pneumatic power disconnect device**

The compressed air isolation device, as can be seen in the "pneumatic diagram" supplied with the machine, is supplied for the sole source of the machine compressed air supply and is of the "isolating shut-off valve" type. This device is identified with the wording, visible in normal conditions of use, "PNEUMATIC SUPPLY ISOLATOR DEVICE".

The unit is located outside the machine's base.

## 4.2. WORKSTATIONS AND OPERATORS' TASKS

The machine described herein is designed to be run by 1 operator suitably trained and instructed with regard to residual risks. The operator must have the same skills, in terms of safety, as the maintenance technicians and adequate professional competence. The normal work area of the operator and relevant tasks/assignments are:

- The manual introduction/removal of mouldings onto the working bench, with the fixed safety guards closed and locked.
- the manual loading of V-nails in the magazine, with the fixed safety guards closed and locked;
- the adjustments and tooling of the key units (head, frontal clamp, alignment fences, etc.) needed to operate the machine, using the relevant tools, with the fixed guards closed and locked;
- the manual removal of V-nails clogged in the magazine and/or nailing claw head, with the fixed safety guards closed and locked;
- check operations (for example reading the data on the console panel and machine instrumentation). These are very simple tasks which can be carried out in total safety and clearly described in the Instruction Manual;
- General monitoring of machine operation - for example checking the cleanliness of the machine, etc. In the event of a problem, the operator must not intervene, but simply call the Maintenance Service;
- Cleaning external and internal machine parts, and any other parts that may require cleaning (e.g. the upper/surrounding part of counter-rotating rollers) via the fixed safety guards, while these are closed and locked. Any cleaning of internal machine parts which requires the removal of the fixed guards must be performed by a qualified maintenance technician.

The operator is responsible for the operating process, and must control the machine by means of the command actuators located on the control panels.

Apart from normal machine operation, the operator must also start and stop the machine in normal conditions, and stop it in emergency conditions.

The operator must also carry out checks and general monitoring operations while the machine is running. In the event of a problem he/she must not intervene, but simply call the Maintenance Service.

All operations performed by the operator must be carried out with all protection devices activated, all guards in place, and all safety devices engaged in order to prevent the risk of injury to arms, legs and other body parts.

All handling operations, preparation, adjustments, installation and connection of power supplies, along with fine-tuning and operating checks, must be carried out by trained, skilled maintenance personnel.

All maintenance and control operations must be carried out by trained and skilled maintenance personnel.

All installation and hook-up operations must be carried out using suitable equipment and tools of an appropriate size (e.g. a slotted or Phillips screwdriver, hex wrenches, Allen keys, etc.), depending on the type of fasteners.

Before carrying out any installation or hook-up operation, the machine, the on-board components must be thoroughly cleaned.



### **DANGER – CAUTION**

**Unless otherwise specified in the contract and clearly indicated in the technical specifications of this Manual, the machine is not suitable for use in environments different to those permitted and duly specified in this Manual.**

The main hazardous work areas of the machine, that may produce risks for the operator, are:

- The area on which the frames are placed is known as the “operating area”.
- The machine’s danger zones are those areas containing moving parts and their immediate vicinity. The main hazardous work areas of the machine, that may produce risks for the operator, are:
  - the area beneath the stopper, inside the magazine and near the head;
  - The area inside the machine during adjustment, tooling and cleaning operations.

Schematic indications of the danger zones for machine fitters:

A. area under the stopper;

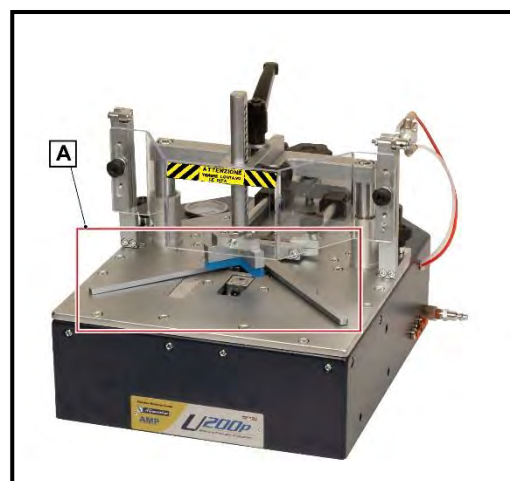

### 4.3. CHECKS, ADJUSTMENTS AND START-UP

All functions/operations pertaining to operating modes must always comply with safety measures and the prescriptions for the protection against residual risks.

During normal production, the machine must only be used to process the products specified herein.

During the working cycle, it is essential to comply with safety measures and prescriptions for the protection against residual risks

### 4.4. START-UP

Before connecting the machine to the pneumatic system, you must first connect the control pedal.

The three air lines connected to the pedal assembly must be inserted in the three connectors located on the right-hand side of the machine in the following order:

- 1) RED LINE on the outer side connector (1) (pedal supply)
- 2) BLACK LINE on middle connector (2) (vertical clamping)
- 3) TRANSPARENT LINE on the operator side connector (3) (hammer)

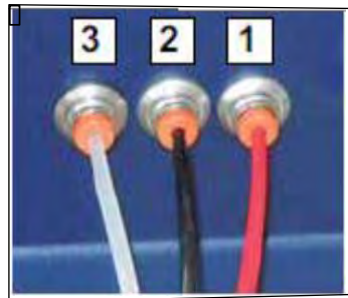

### Inserting V-nails in the loader

To load the V-nail magazine, proceed as follows:

- Draw the V-nail pusher back using the relative control cable located on the rear side of the machine's working bench (1).
- Insert the V-nail stick, making sure that the sharp end of the V-nails is pointing upwards (silicone side) and that it is positioned as indicated in the figure (2).
- Also check that the height of the V-nails is compatible with the firing head installed (3).
- Release the control cable and let the V-nail pusher (1) move forward.

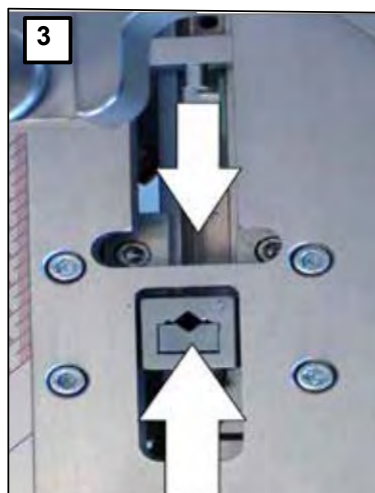
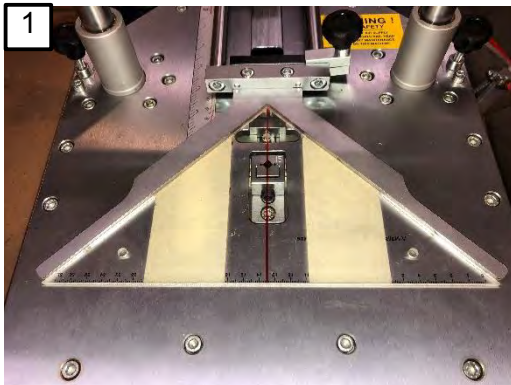



### Changing over the firing head for V-nail changeover.

It is necessary to switch over the nailing head each time a different size V-nail is used.

To replace the head proceed as follows:

- Loosen the firing head locking screw using a suitable wrench (the screw is on the opposite side to the V-nail magazine) (1)
- Lift the head upwards and out.
- Draw the V-nail pusher back by pulling the control cable on the rear side of the machine's working bench to make the magazine accessible (2).
- Remove all the V-nails in the magazine (use the pencil magnet (3) if necessary).
- Insert the new head to match the height of the V-nails to be used (5).
- Tighten the firing head locking screw.
- Insert the new V-nails of the required height in the magazine (4)
- Release the control cable and let the V-nail pusher move forward.

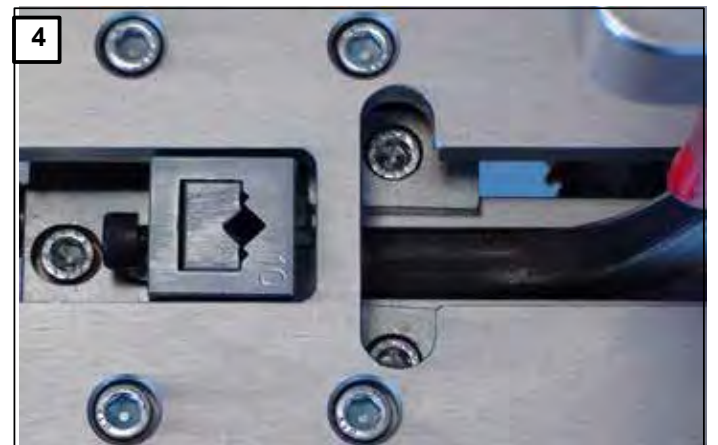
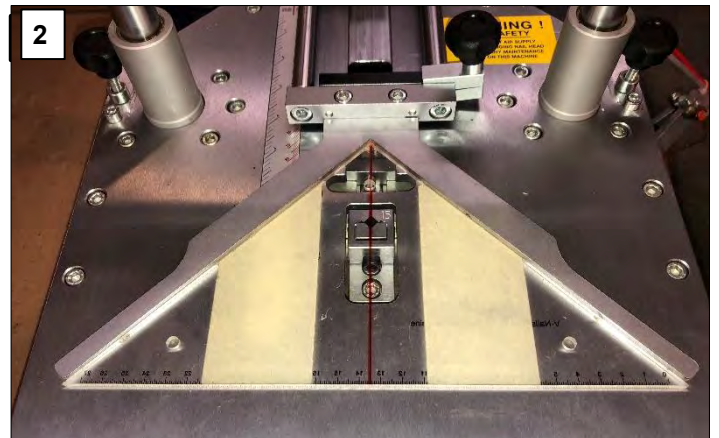

## V-nail firing head alignment

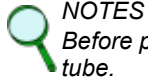

### NOTES

Before proceeding with the operations provided below, disconnect the machine from the compressed air supply and disconnect the tube.

Mechanical alignment of the V-nail firing head is necessary following: loosening caused by work operations, wear on components, jamming during firing, replacement of parts, maintenance. The parts which need to be aligned with one another are: head, L-block support, V-nail magazine and loader.

To perform mechanical alignment, proceed as follows:

1. Undo the socket head screw securing the head to the L-block support and remove the head from the support.
2. Loosen the screws securing the L-block support to the firing unit.
3. Slacken the M5 screws on the two magazine locks.
4. Without forcing it, move the L mount up to the hammer, check that the two parts are snugly in contact, then tighten down the hex screws. Without forcing it, move the magazine up against the hammer after having loosened the two M5 screws locking the magazine in place.
6. Check that the coupling between the V-nail magazine and hammer is perfect.
7. Tighten the M5 screws which lock the magazine in place.
8. Insert a V-nail in the magazine, move it up against the L-block support to check that the wings of the V-nail are perfectly in line with the guide.
9. Replace the head on the L-block support taking care to ensure it is perfectly resting on it and then lock in place with the relative screw then connect the compressed air supply to the machine and switch on.
10. Insert a stick of V-nails in the magazine and command V-nail firing (with no moulding) to check correct expulsion of the nail. The V-nail must run precisely between the L-block support and the head with minimum play and without any resistance.

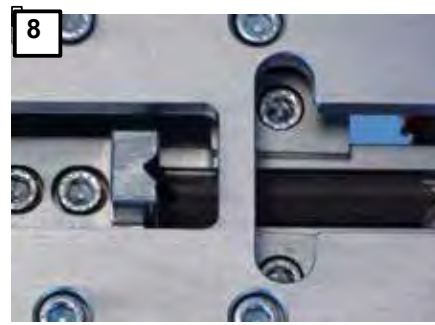
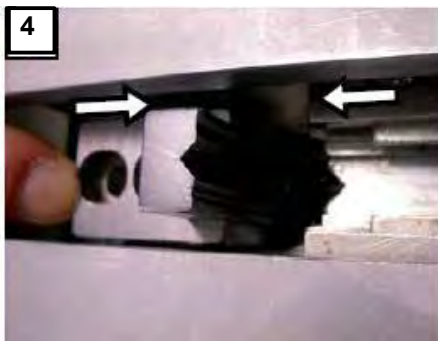

### Adjustment and alignment of the mobile fence

1. Move the transparent fence up to the mobile fence (A). Check that when the fence moves its bisector is aligned with the centre of the V-nail firing head.

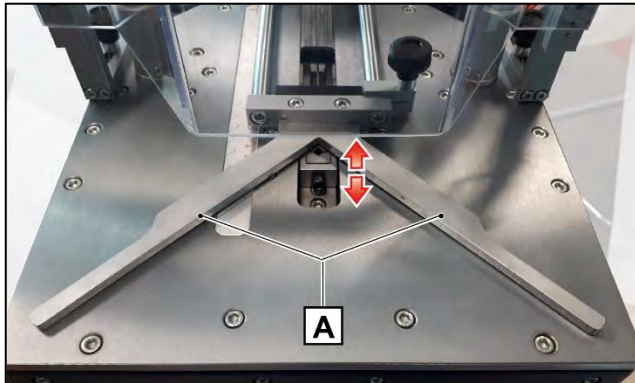

If it is not aligned, proceed as follows.

2. Turn the machine over and slacken the screws (B) relative to the blocks (C) which lock the fence guide blocks to the workbench.

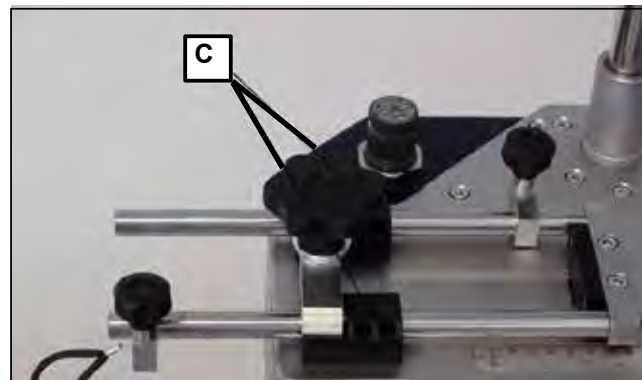
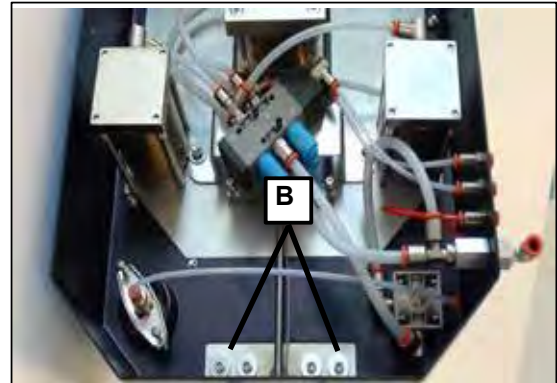

3. Repeat alignment with the transparent fence (A).

4. Tighten the screws (B).

### Adjustment of V-nail insertion positions

For correct positioning of the mouldings to be joined together, the U200P is fitted with a 90° fence.

The fence may move forward or be drawn back (6) in order to correctly position mouldings of various sizes.

The fence forward (8) and fence back positions can be fixed by locking it in the required position using the stopper clamps A-B (8).

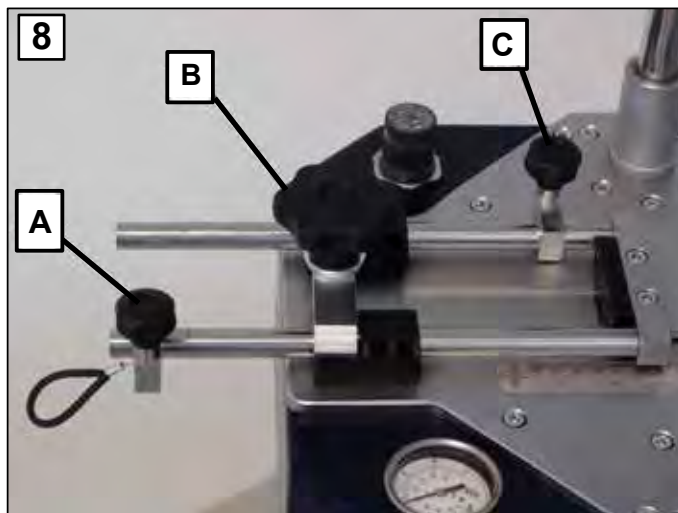
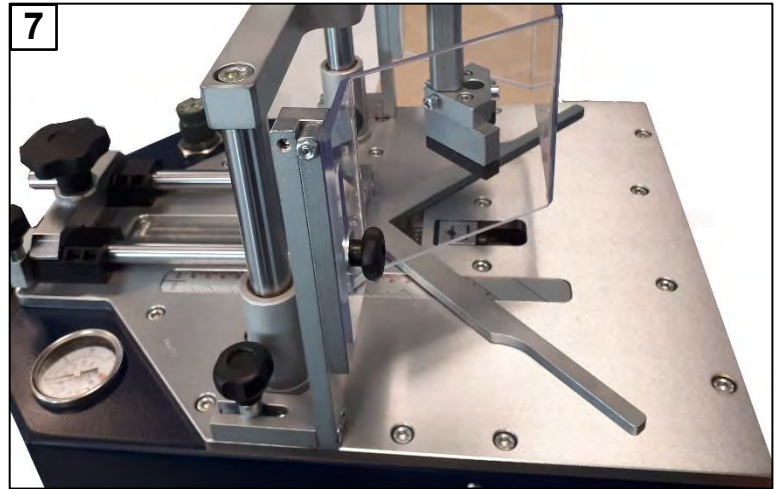
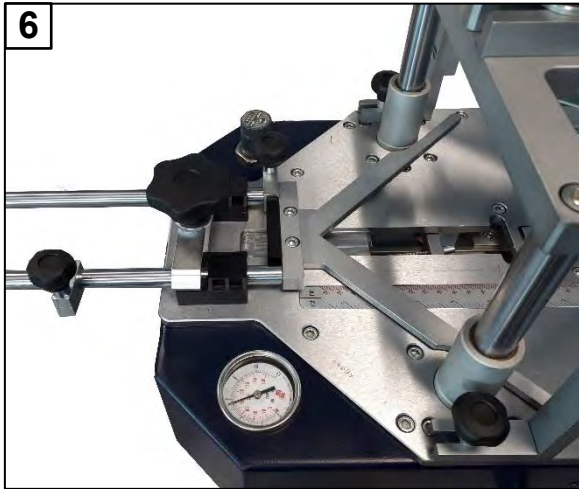

In this way the operator can easily use the U200P to insert V-nails with maximum precision in all the positions between the two mechanical stops (7 and 8).

(A) This picture shows 4 V-nails inserted along the joint between two mouldings;

(B) Depending on the thickness of the frame, two or more V-Nails of the same type can be inserted in the same point.

Knob (B) used to lock the mobile fence.

**A**



**B**



**Fixed fences, optional****Replacing fixed fences with a two-knob mobile fence**

To replace the fence unit, proceed as follows:

1. Remove the guard panel to facilitate the replacement operation by slackening off and removing the two knobs
2. Undo the 2 socket head screws (A).
3. Once the screws have been removed (A) the fixed fence of the machine is removed.
4. To install new fences repeat the above steps in reverse order and tighten the 2 socket head screws.
5. If necessary remove the contact edges from the old fence and transfer to the new one if the latter is without. Do so with the two screws (B) shown in the figure. In this case, make sure the fence is equipped with threaded holes for mounting the 2 knob fence.

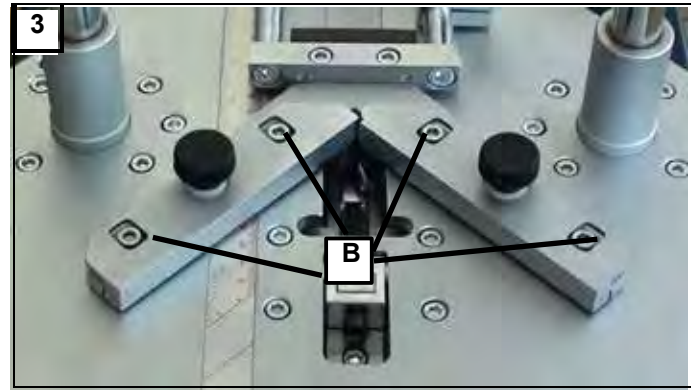
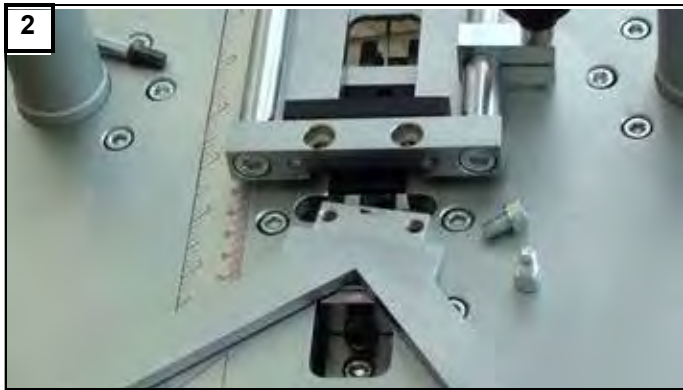
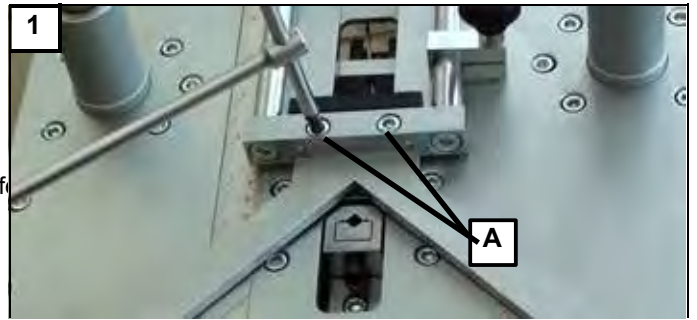
**Fixed fences, optional**

1. To vary the contact angle it is necessary to replace the fixed fence with one of the right angle. The fence for 90° joins (four-sided frame) is part of standard machine equipment. By installing the optional fence (C) the machine can be used to make 120° joins (six-sided frame). By installing the optional fence (D) the machine can be used to make 135° joins (eight-sided frame).

**NOTE:** the declared stroke of the machine (160mm) is determined based on the use of the standard 90° fence. If fences with other angles are used (120°, 135°), the stroke is reduced due to the additional encumbrance.

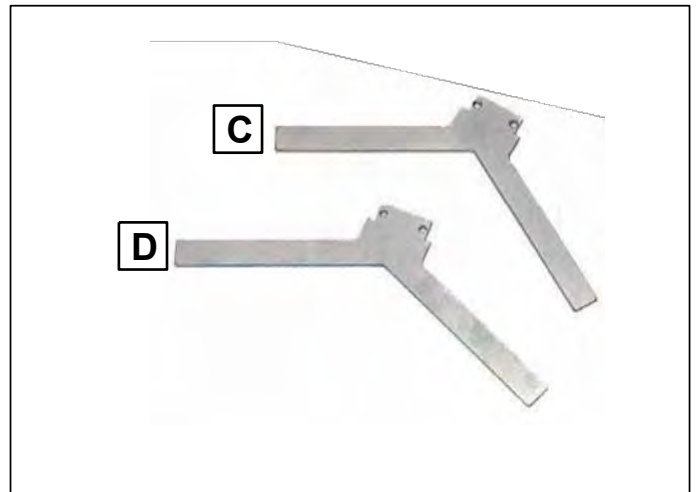

**Adjusting the height and replacing the vertical clamp stopper**

<b>E</b>	<i>Interchangeable rubber stoppers: soft (blue); medium (yellow); hard (black);</i>
<b>F</b>	<i>Single stopper holder</i>
<b>G</b>	<i>Magnetic stopper holder</i>
<b>H</b>	<i>Magnetic support</i>
<b>I</b>	<i>Round magnetic felt stopper.</i>

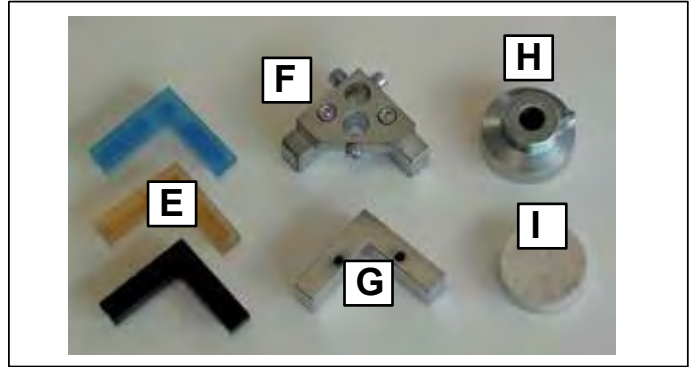

1. To adapt the position of the stopper (E) to the thickness of the frame, proceed as follows:
  - a. pull the click knob out.
  - b. lift or lower the punched rod based on requirements.
  - c. release the click knob to block the column.
2. To replace the stopper holder (F, G or H), you must unscrew the screw (I) which secures it to the rod and pull it downwards and out.

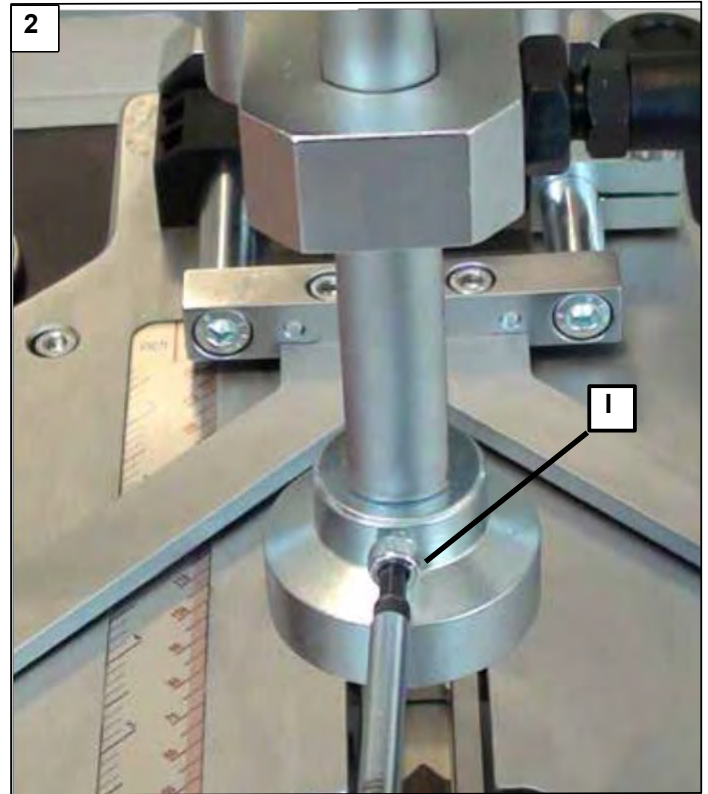
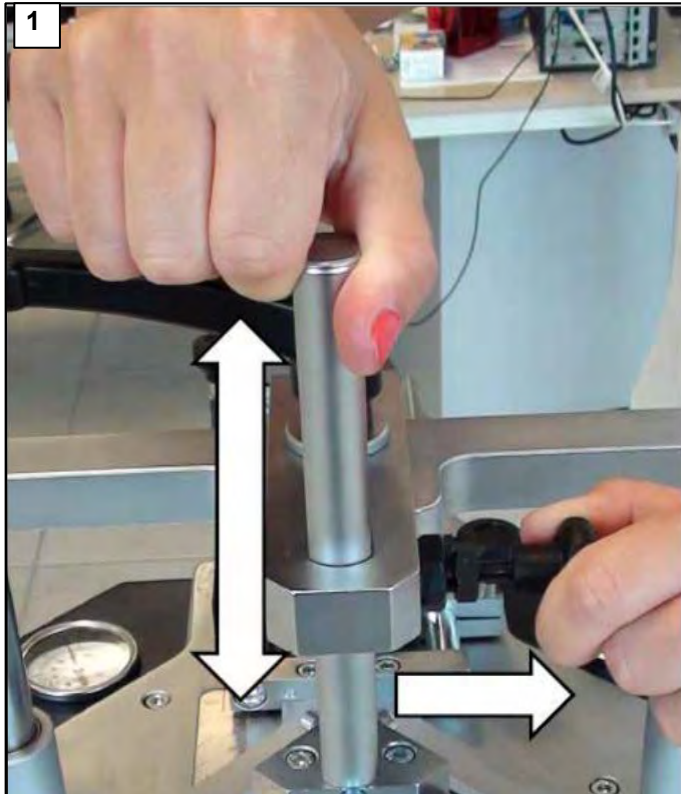

- In the case of a magnetic stopper holder, tighten the socket head screw (I).

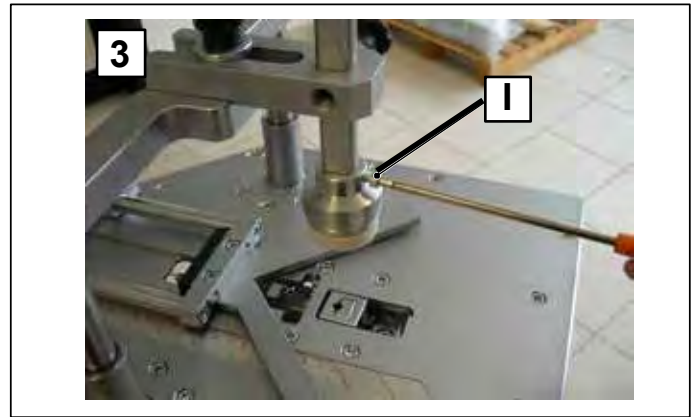

- In the case of a mechanical support, tighten the socket head screw (I).

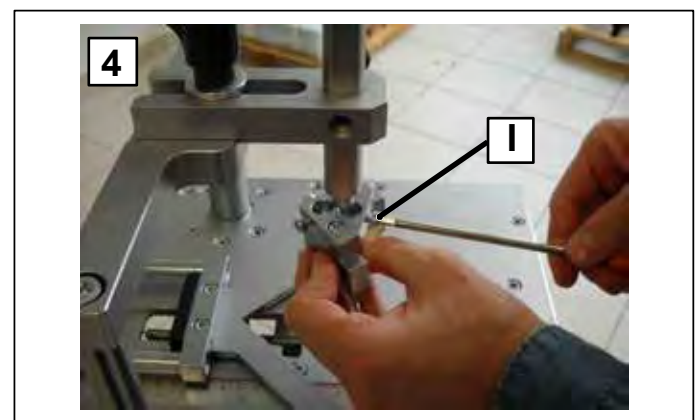

- Insert the interchangeable rubber stopper (E), depending on the required hardness, by inserting it into the stopper holder support.
- Check the correct position of the stopper by positioning it like the 90° fence and tighten the fixing screw (I.).

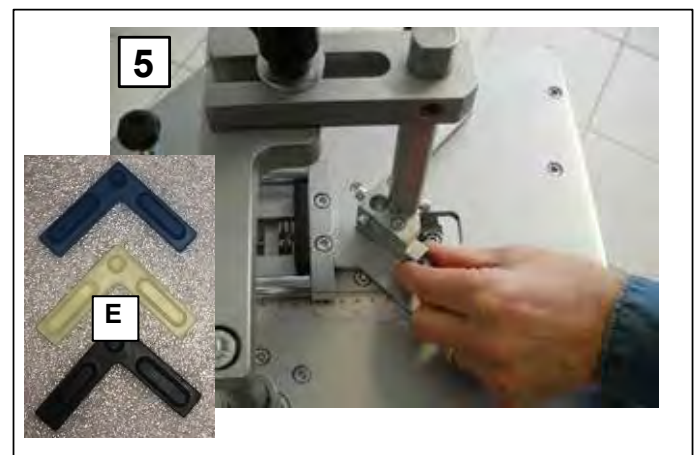

### **Installation of interchangeable stoppers**

The interchangeable stoppers (E), based on work requirements, may be applied to:

- corner magnetic stopper holder;
- single stopper holder;

Install the stopper (E) for the required hardness in the stopper holder, positioning it under the slot and pressing it lightly into place

To remove the stopper (E) simply pull it out with your hand by gently taking hold of one of the two sides.

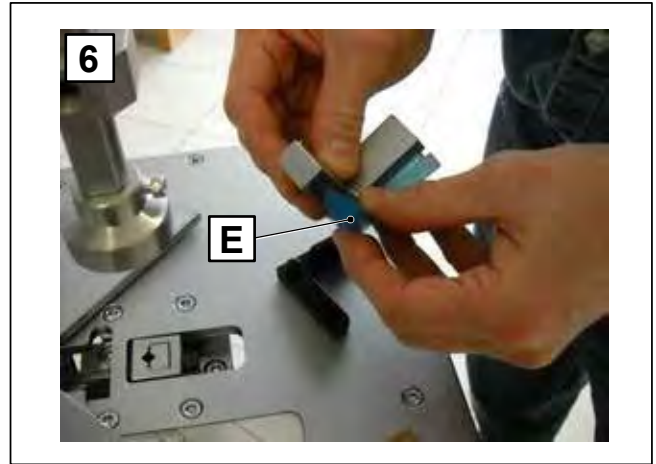

### **Stopper position adjustment**

- Position the mouldings to be joined on the working bench.
- Select the most suitable stopper for the frame moulding and arrange it on the magnetic support.
- Loosen, using the handle above (1 and 2), the clamp which locks the stopper holder rod to allow for forward and backward movements in order to position the stopper directly in line with the V-nail insertion point.
- Tighten the clamp handle in the selected position.

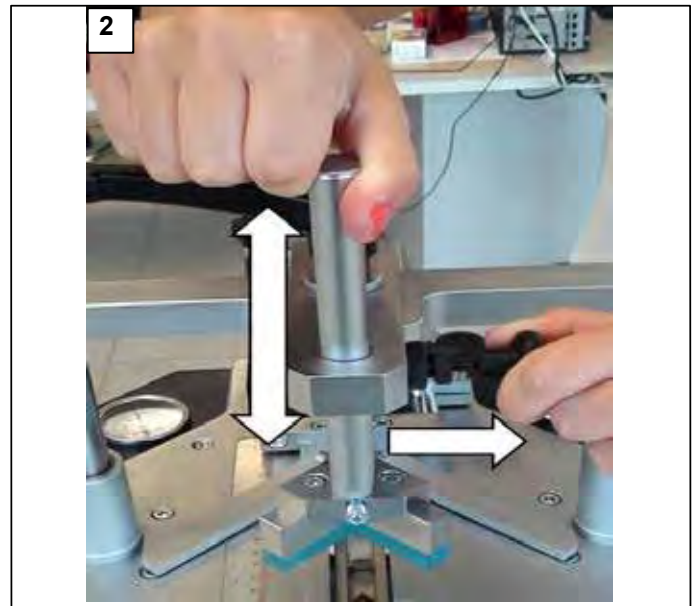
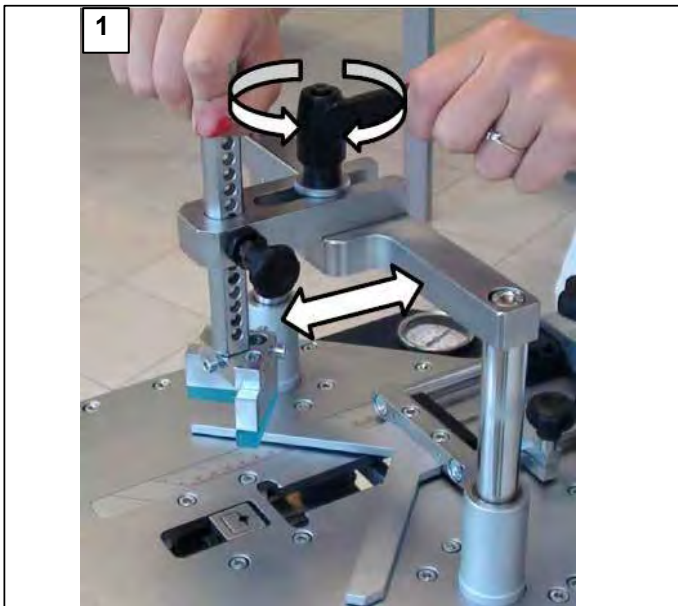



### **Adjusting the pressure of moulding clamping devices**

The procedure for adjusting the pressure of the vertical and front moulding clamping devices is described below. The work pressure must be suitable for the hardness of the mouldings to be joined.

Adjust the clamping pressure in such a way as to avoid crushing or damaging the surface of the material to be joined, but ensuring that the thrust of the hammer for inserting V-Nails does not cause the moulding itself to rise.

The harder the material to be joined, the greater the pressure that can be applied to the clamping devices is.

To correctly assemble the mouldings, the operator must always check they do not rise when V-nails are being inserted. An excessively low work pressure may result in the incomplete insertion of the V-nail in the frame.

The work pressure is adjusted by turning the pressure regulator knob (A) located on the working bench. The work pressure value can be seen on the pressure gauge (B).

To alter the work pressure, proceed as follows:

1. Lift the knob by about 3-4mm.
2. Turn it clockwise to increase the pressure, or anticlockwise to reduce the pressure.
3. Press the knob to lock it back in place.

The following operating pressure values are recommended:

<b>Durezza / Hardness</b>	<b>Pressione consigliata / Air Pressure</b>
Soft Wood <i>Soft Wood</i>	2 bar / 30 psi 4 bar / 58 psi
Medium/Hard Wood <i>Medium/Hard Wood</i>	4 bar / 58 psi 6 bar / 87 psi
Very Hard Wood <i>Very Hard Wood</i>	6 bar / 87 psi 8 bar / 115 psi

Pressure regulation is carried out manually, so it is possible to use any intermediate value between those indicated.



#### **NOTES**

*Increase the pressure by about 10 - 20% for H15 or overlapping V-Nails. The pressure values indicated in the table are purely indicative and may be subject to variations depending on the types of materials being handled.*



**SUGGESTIONS FOR MAKING PERFECT JOINS**

1) V-nail types

In order to ensure that the machine can make top quality joins using a wide variety of materials, different V-nails are available with different degrees of sharpness suitable for use with different hardness values and characteristics of the materials being handled. V-Nails can be divided up into the following categories:

V-nail type	Height mm
H3	3mm (optional)
H5	5mm
H7	7mm
H10	10mm
H12	12mm
H15	15mm

it is advisable to carry out a check on the material in question for selecting the most suitable sharpness.

2) Stapling positions

The following guidelines are designed to help you get the best results in terms of quality joins:

- Avoid inserting V-nails close to the moulding edge. The minimum recommended distance from the outer edge is at least 10mm.
- When creating a joint with just one V-Nail, position the V-Nail on the centre line of the frame.
- If you wish to insert 2 or more V-Nails for each joint, it is advisable to insert the outer V-Nail at 1/3 from the outer edge and the inner V-Nail 1/4 from the inner edge.

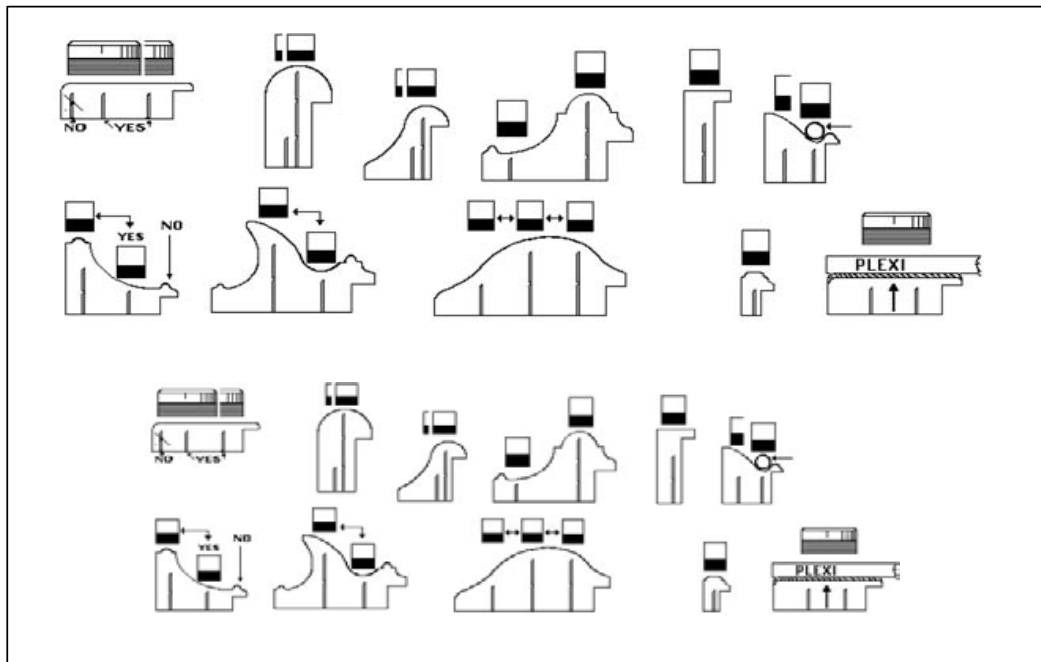

### Adjusting the working bench (IF OPTIONAL STAND PURCHASED)

The machine working bench can be tilted simply by changing the position of the screws responsible for fixing the machine to the stand in the uppermost position.

This operation must be performed using one hand to counterbalance the machine and prevent the working bench from tipping toward the travel stop due to gravity. The machine can be set up as required in the following positions:

- Working bench tilted backwards
- Working bench horizontal;

- Once adjustments have been made, tighten the screws securely to block the machine in the selected position.



### 4.5. PRELIMINARY PROCEDURES

#### Checks to be performed before starting work

After having correctly installed the machine as previously described, check that:

- the mouldings to be joined are correctly positioned on the working bench.
- the magazine holds V-nails which are suitable for the mouldings being joined;
- the firing head is of the right size for the selected V-nails;
- the adjustment of the vertical stopper is suitable;
- vertical clamping is perfect when the profile is positioned and the pedal pressed halfway down,
- adjustment of the V-nail insertion position is correct.
- press the pedal all the way down to insert the V-nail.



*NOTE – Whenever you wish to insert two or more V-nails overlapping in the same position, you must release the pedal halfway up and then press all the way down again to fire the second V-nail.*



#### **DANGER – CAUTION**

*During normal use, the machine must only process the products/materials indicated in this manual.*



#### **DANGER – WARNING**

**THE MACHINE MUST BE SWITCHED OFF AFTER USE.**

**THE COMPRESSED AIR LINE MUST BE DISCONNECTED.**

**PNEUMATIC ACTUATORS MAY HOLD ACCUMULATED ENERGY WHICH MUST BE DISCHARGED OF PRESSURE TO AVOID HAZARDOUS UNEXPECTED MOVEMENTS.**

If there is a filter unit, turn the knob to discharge the machine's compressed air circuit and then disconnect the compressed air line.

### 4.6. WORKING CYCLE



#### **DANGER – CAUTION**

*During normal use, the machine must only process the products/materials indicated in this manual.*

Safety measures and the indications on residual risks must always be observed during machine operation. Insert the compressed air supply connector directly into the machine.

Check that the V-nail magazine is full and that the head corresponds to the height of the V-nails and is correctly installed.



Connect the pedal and make sure the various pneumatic lines have been inserted in the correct sequence.

- 1) RED line in the connector on the outer side (1).  
(pedal).
- 2) BLACK line in the intermediate connector (2)  
(vertical clamp).
- 3) TRANSPARENT line in the connector on the operator side (3).  
(Hammer control)

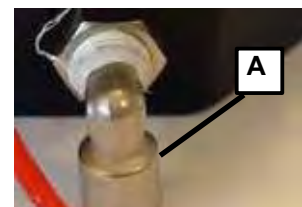
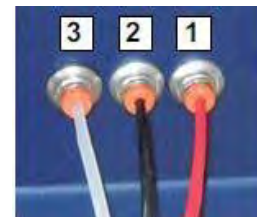

Make all the necessary regulations based on the dimensions of the mouldings, as follows:

- vertical stopper adjustment;

Whenever the two-knob fence is being used, insert the first moulding on the right-hand side of the fence and then bring the left-hand moulding (error condition).



The pedal has three positions:

Position 1 – Stand-by

Position 2 – Pressed halfway down to automatically activate the vertical clamping. Position 3 – Pressed all the way down commands the hammer for V-nail insertion.

Release the pedal for the new V-nailing position and repeat the operation.

1. Taking care over the hazardous areas, use your hands to accompany the movement of the fences and the mouldings up to the desired V-nail insertion position.
2. Press the pedal halfway down to activate vertical clamping.
3. Press the pedal all the way down to insert the V-nail.
4. Lift the pedal to the halfway point (2) to clamp the frame and then press all the way down again (3) to insert the other V-nails in the same place.
5. Completely lift the pedal to release the moulding and reposition the fences as required.
6. Repeat the operation.



To make a joint, proceed as follows:

1. using the stopper blocks on the fence, determine the V-nail insertion positions;
2. position the mouldings on the working bench pushed up against the fence on the first insertion point;
3. adjust the position and height of the vertical stopper;
4. press the pedal (2) halfway down to clamp the frame and check the mouldings are properly positioned and clamped;
5. press the pedal (3) all the way down to insert a V-nail (if the profile of the mouldings needs two or more V-nails in the same position, release the pedal (2) halfway, and then press all the way down again to insert a second V-nail and so on);
6. release the pedal (1) completely;
7. move the mouldings together with the fence to the next insertion point and repeat steps 5, 6, and 7.

## 5. MAINTENANCE, TROUBLESHOOTING, AND CLEANING

### 5.1. MAINTENANCE TECHNICIAN REQUIREMENTS

The term "maintenance" does not just cover periodical controls of normal machine operation, but also the analysis and consequent rectification of any of those problems which for any reason stop the machine from working properly or not at all. Specifically, personnel appointed to perform the servicing, cleaning, replacing of parts and troubleshooting, must work in compliance with the following aims:

1. limit the deterioration of wear parts.
2. reduce accidents to the absolute minimum.
3. reduce costs arising from faults.
4. limit the number and duration of interventions.
5. work in collaboration with the line operators to improve the efficiency of the plant.

### 5.2. WORK STATIONS AND MAINTENANCE TECHNICIAN DUTIES

The maintenance technician duties are:

- to perform tooling operations and adjust mobile parts on the machine,
- to calibrate, adjust and clean internal machine parts,
- to clean the inside of the machine (disassembling parts if necessary), carry out maintenance, lubrication, assistance operations, troubleshooting and the replacements of worn or damaged parts or structural elements.

The work zones that may present risks for the machine's maintenance technician are the following:

- the area relative to tooling, calibration, adjustment, lubrication, troubleshooting, worn and broken part replacement operations, as indicated in this instruction manual;
- the areas in and around the machine during the movement of mobile parts,
- the areas around the air lines;
- the areas around the fixed guards.

### 5.3. MAINTENANCE INSTRUCTIONS

 **DANGER – WARNING**  
**ALL MAINTENANCE, CLEANING AND REPLACEMENTS OF PARTS MUST BE CARRIED OUT SOLELY AND EXCLUSIVELY WITH THE MACHINE DISCONNECTED FROM ALL POWER SUPPLIES.**

It is prohibited to perform any maintenance work on parts that are in motion.

### 5.4. GENERAL WARNINGS

**DANGER - WARNING**

 **BEFORE DOING ANY MAINTENANCE, CLEANING, REPLACEMENT OF PARTS AND TROUBLESHOOTING, PAY THE UTMOST ATTENTION TO THE DECALS AFFIXED TO THE MACHINE.**

 **DURING ALL ACTIVITIES DO NOT TAMPER WITH OR DEACTIVATE ANY OF THE SAFETY DEVICES FOR ANY REASON, EITHER TO CREATE BYPASSES OR TO USE THEM FOR PURPOSES OTHER THAN THEIR INTENDED USE AS PRESCRIBED BY THE MANUFACTURER.**

After performing any of the above tasks on the machine, reset and reactivate all the safety devices.

Do not tamper with or deliberately damage the protective screens nor remove or conceal the warning notices. In the event of deterioration or illegibility of the safety decals immediately order replacements from the equipment supplier.

**DANGER - WARNING**

 **BEFORE PROCEEDING WITH MAINTENANCE, CLEANING AND/OR THE REPLACEMENT OF PARTS, ALWAYS PUT UP A SIGN WHICH IS CLEARLY VISIBLE INDICATING THAT MAINTENANCE OPERATIONS ARE UNDERWAY AND THAT THE MACHINE CAN ONLY BE RESTARTED AFTER HAVING DULY ASCERTAINED THAT ALL OPERATIONS HAVE BEEN COMPLETED AND ALL SAFETY GUARDS HAVE BEEN REPLACED.**

### 5.5. ISOLATION FROM EXTERNAL ENERGY SOURCES

During maintenance, cleaning and replacement of parts, the machine must not be used and no commands must be transmitted.

Before performing any maintenance, lubrication, cleaning and replacement of parts etc. external energy supplies must be disconnected.

All disconnecting devices must be padlocked in the "0" (OFF) position. Turn the knob to discharge residue pressure from the pneumatic system and disconnect the compressed air line.

### 5.6. ROUTINE MAINTENANCE

Personnel responsible for carrying out the operations described in this chapter must have read, understood and consequently observe all the safety prescriptions, in particular:

1. waiting for the stopping times, before inserting limbs or parts of the body into the machine danger areas,
2. the adequate use of personal protective devices and safety accessories needed to perform cleaning operations inside the machine's danger areas,
3. It is prohibited to perform any repair or adjustment work on moving parts,
4. before performing any maintenance, cleaning and replacement of parts, the machine must be isolated from all energy supplies. Furthermore, all general rules must be observed to keep the machine in perfect working order:
  1. keep the machine clean and tidy,
  2. avoid all damage,
  3. avoid a situation wherein make-shift or urgent repairs become commonplace,
  4. do not perform work on the machine which produces swarf; for example, should it be necessary to drill holes, carefully check that no residues end up in machine parts
5. for disposal of worn or replaced materials, observe the relative legislation in force.

## 5.7. TASKS THAT CAN BE PERFORMED BY THE OPERATOR

A list of all the periodical checks/inspections, adjustment and control operations and ROUTINE MAINTENANCE operations which can be carried out by the machine operator is provided below.

The position of the machine components is shown in the layouts enclosed with this manual.

FREQUENCY	CHECK	METHODS AND RESULTS
<b>Before each shift</b>	Working area: <ul style="list-style-type: none"> <li>• must be clean and free from dust</li> </ul>	<p>The work station and all the parts outside the machine must be cleaned and all dust and objects must be removed which could impede correct operation and/or compromise the machine's original safety conditions.</p> <p>Remove all shavings from the machine with a jet of compressed air and lint-free cloths.</p> <p>For any type of intervention or to replace parts, call in the maintenance service.</p>
<b>Before each shift</b>	Check operation: <ul style="list-style-type: none"> <li>• of the emergency stop device;</li> <li>• of the command/control devices relative to safety;</li> </ul>	<p>At the first sign of problems it is necessary to remedy the situation by implementing an inspection procedure to check the correct mechanical operation of the devices.</p> <p>For any type of intervention or to replace parts, call in the maintenance service. Parts must always be replaced using original spare parts or at least parts which provide equivalent quality and safety .</p>
<b>Before each shift</b>	Visual inspection of the condition: <ul style="list-style-type: none"> <li>• of the fixed guards</li> </ul>	<p>All fixed guards must perform the function they were designed for.</p> <p>Check their integrity, both internally and externally and make sure there are no signs of wear or breakage.</p> <p>For any type of intervention or to replace parts, call in the maintenance service.</p>
<b>When necessary</b>	Visual inspection: <ul style="list-style-type: none"> <li>• jammed V-nails</li> </ul>	<p>During operation it is possible that V-nails come out of the magazine and remain in circulation near the nailing head. Remove them using the magnetic pen provided.</p> 
<b>At least once a week</b>	Visual inspection of the condition: <ul style="list-style-type: none"> <li>• of all dataplates</li> </ul>	<p>If they become unreadable new ones must be requested from the manufacturer or they must be replaced by the user with others carrying the exact same information.</p>

Parts must always be replaced using original spare parts or at least parts which provide equivalent quality and safety . The instructions concerning the replacement are not given in this manual and they must therefore be explicitly requested from the machine manufacturer, which reserves the responsibility for the replacement interventions.

## 5.8. TASKS THAT CAN BE PERFORMED ONLY BY MAINTENANCE TECHNICIANS

The ROUTINE MAINTENANCE operations which must be performed by a maintenance technician are indicated below.

The instructions concerning the replacement are not given in this manual and they must therefore be explicitly requested from the machine manufacturer, which reserves the responsibility for the replacement interventions.

FREQUENCY	CHECK	METHODS AND RESULTS
Every 1,000,000 V-nails used	Check / replace: Hammer	Replace every 1,000,000 V-nails used

1. Turn the machine over to gain access to the pneumatic equipment.



2. Disconnect the air supply from the machine. Remove the 4 socket head screws which secure the pneumatic cylinder to the head.

3. Remove the pneumatic cylinder and extract the hammer if it is still inside it. Remove all traces of dirt, clean with degreaser, check for wear, grease all the internal surface.

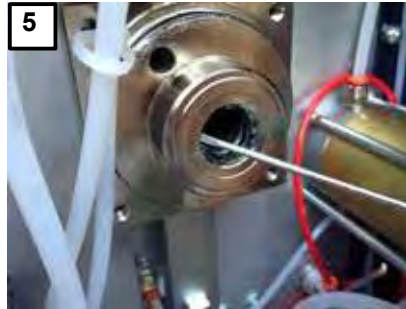

4. Replace the external head seal with the aid of a screwdriver. Clean the seal seat thoroughly and grease.

5. Replace the lip seal inside the head with the aid of a screwdriver. Clean the seat and the bush hole thoroughly and grease.

6. Remove the seals from the hammer, clean well and grease, check for wear or the presence of splinters. Install the new seals making sure the lip seals are placed the right way round.



7. If the hammer is worn out or chipped, proceed to replace the whole piston. The raised ends of the hammer must have marked edges to ensure correct insertion of the V-nail.
8. Grease the hammer piston and the seals well then insert it in the special hole taking care not to pinch the lip seal. If insertion proves difficult, try removing the L-block support, head and V-nail loader.



9. Note: position the hammer so that the high part of the piston has the two raised edges pointing towards the magazine.
10. Replace the cylinder and move it well up against the head. Secure in place with the 4 screws and reconnect the air lines.

At the end of the operation check alignment of the V-nail firing head: magazine and head:

reconnect the air supply to the machine and activate the hammer several times to make sure it moves correctly and that there are no mechanical hindrances.

Insert the loader with the V-nails and fire several times to make sure the V-nails are correctly fired from the head.



FREQUENCY	CHECK	METHODS AND RESULTS
Every 5,000,000 V-nails inserted	Check / replace the "L" support block	Proceed with disassembly by following the instructions in the heading MECHANICAL ADJUSTMENTS / MAINTENANCE
At least once a month		All parts inside the housings and in the motor compartments must be kept clean and dry. Use suitable and normally available tools and equipment (e.g. vacuum cleaners and dry brushes to remove dust and absorbent cloths for removing moisture) to keep said areas of the machine in a suitable operating condition.
At least once a month	<b>Check the effectiveness:</b> <ul style="list-style-type: none"> <li>of the mechanical connections</li> </ul>	Use suitable tools and equipment to check the tightness of terminals, screws, nuts, bolts and connections in general on both the equipment and the machine.
At least once every 3 months	<b>Check reliability and operation:</b> <ul style="list-style-type: none"> <li>of the fixed guards,</li> <li>of the safety equipment.</li> </ul>	<b>The necessary inspections concern:</b> <ul style="list-style-type: none"> <li>loss or damage to any part of the safeguards, especially if this entails a reduction in the safety function it is designed to perform, for example a reduction in resistance to impact caused by scratches/damage to Plexiglas panels.</li> <li>replacement of wear parts;</li> <li>correct operation of the interlocks;</li> <li>deterioration of joints or fixing points;</li> <li>deterioration due to corrosion, temperature variations or chemical effects;</li> <li>satisfactory operation and lubrication of moving parts, if necessary;</li> <li>modification of safety distances and size of openings;</li> <li>deterioration of the acoustic performance, if applicable.</li> </ul> <p>Replacement must be carried out when one of the components indicated displays anomalous wear and at the first sign of cracking, erosion or breakage. Parts must always be replaced using original spare parts or at least parts which provide equivalent quality and safety . Contact the manufacturer directly.</p>

Parts must always be replaced using original spare parts or at least parts which provide equivalent quality and safety .

The INSTRUCTIONS CONCERNING REPLACEMENT OPERATIONS ARE NOT GIVEN IN THIS MANUAL and they must therefore be explicitly requested from the machine manufacturer, who shall remain RESPONSIBLE FOR THE REPLACEMENT OPERATIONS.

## 5.9. CLEANING

### **DANGER – CAUTION**

***It is prohibited to manually clean, oil or grease moving machine parts and elements unless this is strictly necessary for some specific technical requirement. If this is the case all suitable measures must be taken to prevent hazards. Workers must be informed by means of clearly visible warning signs.***

***Cleaning operations which can be performed by maintenance technicians are indicated below.***

Normally, some cleaning operations can be performed by the machine runner; i.e., in the case of normal operations on the outside of the machine that call for the use of simple personal protective equipment..

Cleaning operations of the internal parts of the machine must be performed by the maintenance service.

To avoid inadvertent untimely and hazardous activation of the machine or unwanted and inadvertent modifications of any kind, cleaning operations should be carried out by the same personnel who usually work on the machinery rather than personnel from a cleaning company who may not observe all the recommendations indicated herein.

All cleaning operations must be carried out only after the machine has been cut off from external power supplies and all accumulated energy has been discharged.

### **DANGER – CAUTION**

***Never use petrol, solvents or other inflammable and/or corrosive fluids to clean the machine or its components. Use exclusively commercial, approved non-flammable and non toxic solvents.***

Comply with the methods of use and use all the necessary personal protective equipment specified by the supplier of such substances.

The machine, its on-board components must never be washed with water, especially not in the form of jets of any type or intensity; i.e. it must not be washed using buckets, hoses, or even sponges.

For the identification of the components mentioned and details on their position, refer to the “mechanical components” layout and the layout provided with the machine.

Fixed guards must be removed in order to gain access to some of the parts requiring lubrication.

Fixed guards are identified by the following sign:



Once all cleaning operations have been completed, all the fixed guards must be refitted and secured in place.

Being as the machine is of simple and sturdy construction, it does not require any particular mechanical maintenance.

It is however advisable to adhere to the following indications:

- periodically remove any traces of glue or other residues from the firing head and from the top part of the hammer;
- always keep the V-nail magazine seat clean and free;
- remove any residues which may build up along the support of the V-nail guide (L-block).

The cleaning operations must not be carried out using water as this could lead to oxidization of the metal parts.

## ZONE, MODE AND METHODS

THE WORKING BENCH AND THE FIRING HEAD must be kept clean from all residues of glues used to join the frames. Do not use water. Use a petroleum based cleaning product.

THE V-NAIL MAGAZINE AND GUIDE must be kept clean from any residues and dust. Do not use water. Use a petroleum based cleaning product.

- THE WORKPLACE AND THE CONTROL STATION must be kept clean and tidy. Remove all dust and dirt. An untidy workplace increases the risk of accidents.  
During cleaning operations, always use a dust mask and any other PPE prescribed for the type of operation being carried out and depending on the substances used for cleaning.  
Comply with the methods of use and use all the necessary PERSONAL PROTECTIVE EQUIPMENT SPECIFIED BY THE SUPPLIER OF SUCH SUBSTANCES.
- Avoid using rubbing alcohol, benzene, solvents or any other type of detergent on non-metal parts which, when necessary can be cleaned using a neutral, non-foaming, water-based detergent ONLY .  
If necessary, metal parts can be cleaned using a lint-free cloth dampened slightly with rubbing alcohol, taking great care however not to come into contact with any adjacent or nearby plastic materials. Never use abrasive products, coloured substances, metal scourers, wire brushes, scrapers, etc.
- Comply with the methods of use and use all the necessary PERSONAL PROTECTIVE EQUIPMENT SPECIFIED BY THE SUPPLIER OF SUCH SUBSTANCES.
  
- Remove all rust marks that may have formed on unpainted surfaces during transport or storage.  
For this operation use a specific commercial antirust agent.
- Comply with the methods of use and use all the necessary personal protective equipment specified by the supplier of such substances.
- Remove the double-action purifying filter (centrifugal for capturing large particles of impurities and condensate and filtering for the smaller solid particles suspended in the air) located in the compressed air supply hook-up zone.
- CONDENSATE IS DRAINED by means of the special valve (A) on the bottom of the collection cup (B). The cups can also be taken out for cleaning.
- CONDENSATE MUST ALWAYS BE DRAINED before it reaches the level of the filtering elements or the filter separators.
- When cleaning, do not use synthetic solvent-based degreasing substances.
- Once the filters are clean they can be refitted in the places from which they were removed and the grills must be refitted and fastened in place.

Wear a dust mask during cleaning procedures.

**5.10. LUBRICATION**

During lubrication operations:

1. Avoid bringing oil and/or grease into contact with the skin.
2. During oil and/or grease changes use protective gloves.

Both spent and fresh lubricants are highly polluting: for disposal of lubricants consult your lubricant dealer or contact a specific toxic waste disposal company.

All lubrication operations must be performed:

1. after first cutting off all external energy supplies,
2. strictly observing the safety indications given in the “safety datasheets” provided with each individual lubrication product used.

The lubrication operations which must be performed by maintenance technicians are indicated below.

To obtain high performance and faultless operation, it is important to lubricate moving parts of the machine on a regular basis.

The position of machine components which need lubricating is shown in the layout provided as an appendix to this manual. For the disposal of spent oil and grease, observe the relative legislation in force.

Do not disperse spent oil in the environment. Consign it to specifically authorised collection centres.

**NOTES**

- Fixed guards must be removed in order to gain access to some of the parts requiring lubrication.
- Fixed guards are identified by the following sign:



Once lubrication operations have been completed, all the fixed guards must be refitted and secured in place.

**NOTES**

- We recommend using CASTROL MAGNA GC32 oil or equivalent; no silicone oil
- Lubrication with inappropriate products may damage the seals on the pneumatic devices.

FREQUENCY	LUBRICATION	METHODS AND RESULTS
At least once every six months	Maintenance technician	Lubricate the hammer piston by following the instructions provided in the heading ROUTINE MAINTENANCE.
Every 200 service hours	Hammer piston	Automatic lubrication of the pneumatic actuators. Make sure there is oil in the reservoir of the filter unit.

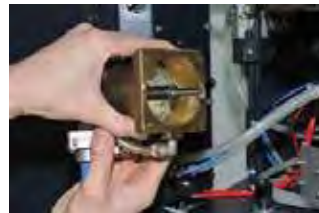

Lubricate the carriage guides located under the working bench.

## 6. TROUBLESHOOTING - RELEASING JAMMED MOVING PARTS

If any of the moving parts becomes jammed, in order to release it in conditions of safety the machine operator must first stop the machine and then inform the persons in charge of maintenance, if he has not been authorised to release jammed parts beforehand. The following section describes operations for troubleshooting and releasing moving parts that can be performed by maintenance technicians. Before performing any work or investigations:

1. Install a sign indicating that maintenance is in progress on the machine
2. Make sure that the upstream and downstream connected machines do not constitute a source of danger or an impediment to the maintenance work; switch off said machines using the designated procedures.
3. Before restarting the machine, make sure there are no personnel still performing cleaning and /or maintenance operations on it.
4. For mechanical repair work, always seek the assistance of the manufacturer.
5. Always consult the machine manufacture in accordance with the methods specified on the initial pages of this manual.
6. Do not zero/reset the safety devices automatically by means of an external sequence without first checking and identifying the cause of the stoppage.

By observing any types of information that the machine control system provides, machine faults can be identified and interpreted. All information devices (visual, audible) aimed at avoiding potential ergonomic hazards, with the relative explanations and the type of information the operator/s will receive are described in chapters 3 and 4.

Depending on the type of information, action must be taken to eliminate the cause that led to/generated the visual or audible alarm signal. The PROBLEMS OR FAULTS which could lead to a MACHINE STOPPAGE are:

PROBLEM / FAULT	POTENTIAL CAUSE(S)	METHODS AND ANCILLARY NOTES
<b>When the pedal is fully pressed and then the button is pressed, the V-nails are not fired properly.</b>	Operating pressure insufficient	<ul style="list-style-type: none"> <li>- Check that the minimum pressure value for the system is over 6 Bar.</li> <li>- Check that the operating pressure value is between 4 / 7 Bar.</li> <li>- Check that the pressure value indicated on the gauge is over 2 bar, value based on the hardness of the material being joined.</li> </ul>
	V-nails badly positioned in the loader.	<ul style="list-style-type: none"> <li>- Check that the sharpened part (edge with glue) is pointing up.</li> <li>- Check the orientation of the V-nails</li> <li>- Check that the top of the "V" of the nails is pointing towards the back of the machine or in the direction of the fences.</li> <li>- Check that the V-nails show no signs of faulty gluing, uneven profiles, etc., replace if necessary.</li> </ul>
	V-nail guide channel (L-block support) blocked or worn.	Check that the V-nail guide channel (L-block support) is not dirty or clogged. Clean if necessary.
	Insufficient thrust from the V-nails pusher	Check that the pressure of the reduction valve which supplies the V-nail pusher cylinder is at least 2 Bar. If necessary, increase it by 10%
	Faulty V-nails	- Replace the V-nails;
	Insufficient air pressure	Check that the air pressure from the compressor is at least 6 Bar.
	V-nail magazine open	Close the magazine by acting on the relative lever valve (ON position) <ul style="list-style-type: none"> <li>- Replace the pedal valve.</li> </ul>
	Faulty valves	- Replace the control valves.
<b>Pressing the button more than once, operation starts out correctly but becomes irregular.</b>	Valves clogged by excess oil or condensate.	Remove any excess oil or condensate from the valves by disconnecting the command lines one at a time and bleeding them of air.
	Faulty valves	Replace the valves if necessary. <ul style="list-style-type: none"> <li>- Replace the pedal valve.</li> <li>- Replace the control valves.</li> </ul>

PROBLEM / FAULT	POTENTIAL CAUSE(S)	METHODS AND ANCILLARY NOTES
<p><b>When the pedal is pressed, the machine works properly, but when the pedal is released, there is a slight delay in the repositioning of the columns and/or hammer.</b></p>	<p>Faulty or clogged valves</p>	<ul style="list-style-type: none"> <li>- Remove any oil and condensate</li> <li>- Replace the pedal valve.</li> <li>- Replace the faulty control valves</li> </ul>
<p><b>When wishing to insert more than one V-nail in the same point, they do not overlap in height or when inserted they end up in a slanting position.</b></p>	<p>Unsuitable V-nails</p>	<p>Change the V-nails for suitable ones</p>
	<p>Incorrect frame clamping (the frame moves around during V-nail insertion)</p>	<ul style="list-style-type: none"> <li>- Check and if necessary correct the position of the vertical stopper and the rod clamp.</li> <li>- Increase the pressure by acting on the pressure reducer</li> </ul>
	<p>Worn hammer</p>	<ul style="list-style-type: none"> <li>- Replace the stopper with a more suitable one</li> <li>- Replace the hammer</li> </ul>
	<p>Obstructed hammer</p>	<p>Clean the top part of the hammer to remove any product which may have clogged the upper profile</p>
	<p>The V-nail firing unit is not at the same level as the working bench</p>	<p>Adjust the V-nail firing unit so that it is at the same level as the working bench</p>
	<p>Check that the "AFC" braking system is working properly</p>	<p>Replace the seals Adjust the stroke of the piston by acting on the relative screw</p>
<p><b>Working in a horizontal position, the carriage tends to go towards the upper stopper and when the lever is pulled towards the bottom stopper it is very difficult.</b></p>	<p>Balancing cylinder powered</p>	<p>Act on the pressure reducer and set the pressure at 0 bar</p>
<p><b>Machine runs noisily.</b></p>	<p>Machine moving parts are not well lubricated.</p>	<p>Check for and remove any jamming of moving parts and/or perform lubrication if required.</p>

## 7. REINSTALLATION AND REUSE



### CAUTION - DANGER

**MOVING AND REINSTALLING THE MACHINE IN A DIFFERENT LOCATION ARE HIGHLY DELICATE OPERATIONS WHICH CALL FOR SIGNIFICANT EXPERIENCE. CONSEQUENTLY TO ENSURE THAT THE OPERATIONS ARE CARRIED OUT WITHOUT ANY RISKS FOR PERSONNEL OR THE MACHINE, THESE OPERATIONS MUST BE CARRIED OUT SOLELY AND EXCLUSIVELY BY PERSONNEL APPOINTED DIRECTLY BY THE MACHINE MANUFACTURER OR AUTHORISED BY THE SAME.**

## 8. EXTINGUISHING MEDIA

The indications on extinguishing media are of fundamental importance as any operations/interventions which are not carried out in compliance with the indications provided below or are not foreseen, may damage the machine, its internal components, the power supply system, the product being handled/produced not to mention injury to operators. Failure to observe the indications will also nullify the warranty.



### CAUTION - DANGER

**ALL OPERATIONS TO PUT OUT A FIRE MUST BE CARRIED OUT BY PERSONNEL WHO ARE ADEQUATELY INFORMED AND TRAINED CONCERNING THE RISKS AND HAZARDS THAT MAY ARISE DURING EXECUTION OF SAID ACTIVITIES. THEY MUST HAVE READ AND UNDERSTOOD THE SAFETY PRESCRIPTIONS PROVIDED IN THIS INSTRUCTION MANUAL AND BE IN GOOD PSYCHO-PHYSICAL SHAPE.**

In the event of a fire affecting parts of the machine, or the processed product, always use a type "C" Co2 extinguisher.

A fire extinguisher of this type must be kept next to the machine work station at all times.

## 9. SCRAPPING AND DISPOSAL



### DANGER - WARNING

**IF YOU DECIDE NOT YOU NO LONGER WISH TO USE THE MACHINE DESCRIBED IN THIS MANUAL BECAUSE IT HAS BECOME OBSOLETE AND/OR IRREPARABLY DAMAGED OR WORN TO A POINT WHERE ANY FORM OF REPAIR WOULD NOT BE AN ECONOMICALLY VIABLE SOLUTION, IT MUST BE PUT OUT OF SERVICE AND RENDERED INOPERATIVE AND FREE FROM ALL POTENTIAL HAZARDS.**

Decommissioning of the machine must be carried out by specialised and suitably equipped personnel.

If the client does not have the right personnel or tools to be able to proceed with demolition of the machine in total safety and in such a way as to safeguard the operators involved, he must seek the assistance of the machine manufacturer's technical staff.

Before starting the scrapping procedures display signs informing persons in the area that work is in progress.

### 9.1. SCRAPPING



#### NOTES

*To be able to perform the necessary tasks in maximum safety, the areas around the machine, for a whole 360° and over a distance of at least 2000 mm, must be free of walls, other machinery, equipment or other elements, such as support pillars, which might get in the way.*

The main sequential stages for dismantling and scrapping include the following (the list is provided as a guideline and is not exhaustive): disassemble all machine components and consign them to an authority or company for differentiated collection in compliance with the relative legislation in force.

All operations to disconnect the machine must be carried out using suitable equipment and tools of an appropriate size (e.g. a slotted or Phillips screwdriver, hex wrenches, Allen keys, etc.), depending on the type of fasteners.

During dismantling procedures do not enter the interior of the machine or climb under or on top of it for any reason: always work while standing alongside the machine.

Before disassembling parts and/or disconnecting and/or loosening any joining elements, take steps to ensure that the connected parts cannot subsequently fall on top of yourself or other exposed persons.

This must be achieved also using ancillary supports or restraints, or approved and certified lifting devices in compliance with statutory legislation in force in your country.

Never carry out dismantling procedures single-handedly. Always make sure there is someone there to provide assistance and/or help in the event of accidents. Said assistant must have the professional training of a maintenance technician or higher.

Pay attention to any decals affixed to the components to be disconnected and next to terminal boxes. When the machine has been fully dismantled all the identification plates of the machine and all documents referring to the machine must be destroyed.

## 9.2. DISPOSAL

**⚠ DANGER – WARNING**  
**DISPOSE OF THE MACHINE COMPONENTS IN ACCORDANCE WITH OPERATING METHODS WHICH OBSERVE THE MAIN REGULATIONS GOVERNING SAFETY AN ENVIRONMENTAL PROTECTION IN THE COUNTRY OF DISPOSAL.**

The machine can be disposed of without having to reduce it to small pieces; simply separate the main units it is made up of and load them onto a lorry for transfer to a scrap merchant.

Clearly, this operation must be performed using adequate lifting and handling equipment including forklifts, hoists, A-frames, overhead travelling cranes, etc., all of which must be approved and certified in compliance with statutory legislation and applicable regulations.

Proceed with disposal operations in accordance with the relative legislation in force by contacting the relative bodies and/or specialized waste disposal companies authorized to handle industrial machinery and/or waste disposal to make sure that all plastics, metal materials and electrical components which must be disposed of separately are duly sorted.

The employer must be aware of all the statutory legislation in force in the country of disposal and must operate in compliance with the relative provisions.

It is prohibited to dump the machine in environment. All violations are punishable by law.

### MANUFACTURER'S IDENTIFYING

#### INFORMATION

ALFAMACCHINE S.r.l.

Address

Via Curie Marie e Pierre, 3 - 47122 FORLI

Tel. +39 0543 783301 Fax +39 0543 783302

Email: customerservice@alfamacchine.com

Name	<b>FRAME ASSEMBLING MACHINE</b>
Function	<b>ASSEMBLY OF FRAMES BY INSERTION OF METAL V-NAILS</b>
Model / Type	U200P
Serial number	
Year of manufacture	
Manual Revision	<b>02</b>

### DOCUMENT

#### INSTRUCTION MANUAL

No. of volumes:

1 Date:

23/02/2024

Revision: 02

© Copyright 2023 - ALFAMACCHINE S.r.l.

Unless expressly authorized in writing by ALFAMACCHINE S.r.l., this manual nor any part of it, may be copied in any form, modified, transcribed, translated into any language, made available to third parties or in any way used in a manner which could have a negative impact on the interests of ALFAMACCHINE S.r.l..

**All violations of the foregoing prescriptions are subject to penalties in compliance with the law and the rules of copyright.**



**TABLE 1 - MACHINE ASSEMBLY**

#	Fig.	Descrizione
<b>U200P CE</b> <b>#178720009</b>		
1	Z252200/10	Vertical clamp cylinder Cilindro bloccaggio verticale
2	Z587100/10	3 way's pneumatic foot pedal Pedale pneumatico a 3 vie
3	TAB.43	V-Nail head assembly Gruppo testa di aggancio
4	TAB.40	V-Nail stick spring pusher Spingipuntì a molla
5	TAB.41	Vertical clamp assembly Gruppo bloccaggio verticale
6	TAB.42	Fence assembly and clamp Gruppo squadra e bloccaggio
7	TAB.43	Pneumatic components Componenti pneumatici
8	TAB.44	CE safety guard Protezione CE
OPT.	TAB.45	Floor stand Supporto macchina

Alfamacchine  
06.2023

**TABLE 2 - INSTALLING THE HEAD UNIT**

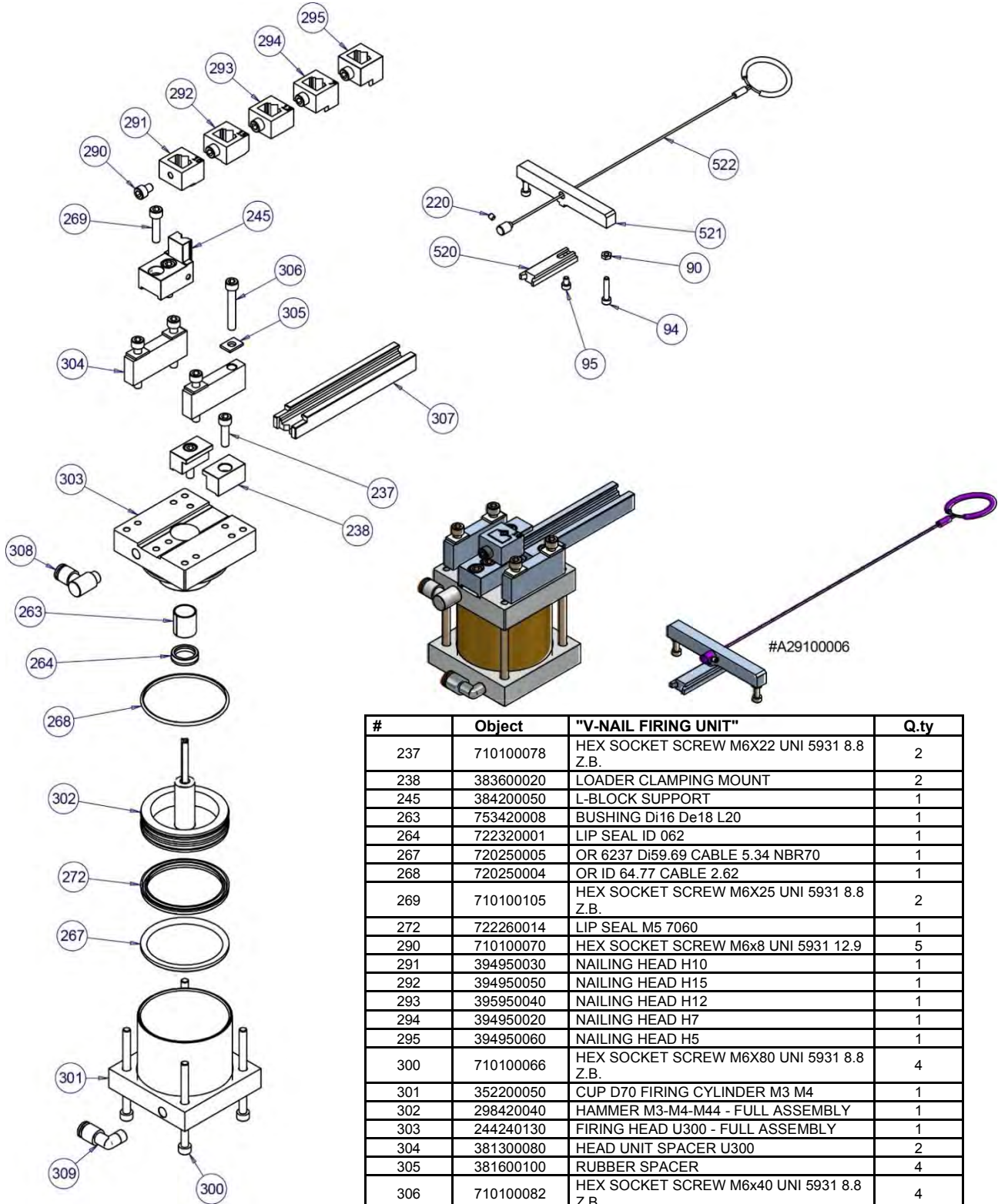

#	Object	"V-NAIL FIRING UNIT"	Q.ty
237	710100078	HEX SOCKET SCREW M6X22 UNI 5931 8.8 Z.B.	2
238	383600020	LOADER CLAMPING MOUNT	2
245	384200050	L-BLOCK SUPPORT	1
263	753420008	BUSHING Di16 De18 L20	1
264	722320001	LIP SEAL ID 062	1
267	720250005	OR 6237 Di59.69 CABLE 5.34 NBR70	1
268	720250004	OR ID 64.77 CABLE 2.62	1
269	710100105	HEX SOCKET SCREW M6X25 UNI 5931 8.8 Z.B.	2
272	722260014	LIP SEAL M5 7060	1
290	710100070	HEX SOCKET SCREW M6x8 UNI 5931 12.9	5
291	394950030	NAILING HEAD H10	1
292	394950050	NAILING HEAD H15	1
293	395950040	NAILING HEAD H12	1
294	394950020	NAILING HEAD H7	1
295	394950060	NAILING HEAD H5	1
300	710100066	HEX SOCKET SCREW M6X80 UNI 5931 8.8 Z.B.	4
301	352200050	CUP D70 FIRING CYLINDER M3 M4	1
302	298420040	HAMMER M3-M4-M44 - FULL ASSEMBLY	1
303	244240130	FIRING HEAD U300 - FULL ASSEMBLY	1
304	381300080	HEAD UNIT SPACER U300	2
305	381600100	RUBBER SPACER	4
306	710100082	HEX SOCKET SCREW M6x40 UNI 5931 8.8 Z.B.	4
307	398350031	LOADER	1
308	730410002	ROT.SING.ANG. ROD QUICK COUPLER R15 8 1/8	1
309	730160006	QUICK-FIT CORNER COUPLER R39 8 1/8	1
#	Object	<b>A29100006 V-NAIL PUSHER</b>	<b>Q.ty</b>
90	715650001	MEDIUM NUT M4 UNI 5588 Z.B.	2
94	710100008	HEX SOCKET SCREW M4X20 UNI 5931 8.8 Z.B.	2
95	710100001	HEX SOCKET SCREW M4X6 UNI 5931 Z.B.	1
220	714300003	HEX SOCKET GRUB SCREW 4x4 UNI 5923 14.9	1
520	A30100025	MAGAZINE SLIDER	1
521	A30100024	MAGAZINE SLIDER MOUNT	1
522	A29100001	CORD D.1.6 FOR V-NAIL PUSHER	1

**TABLE 3 - VERTICAL CLAMPING UNIT**

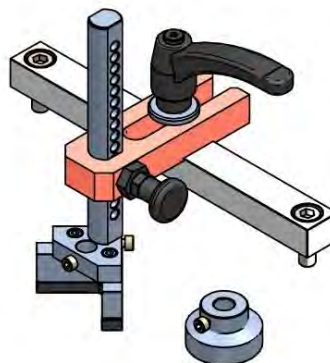
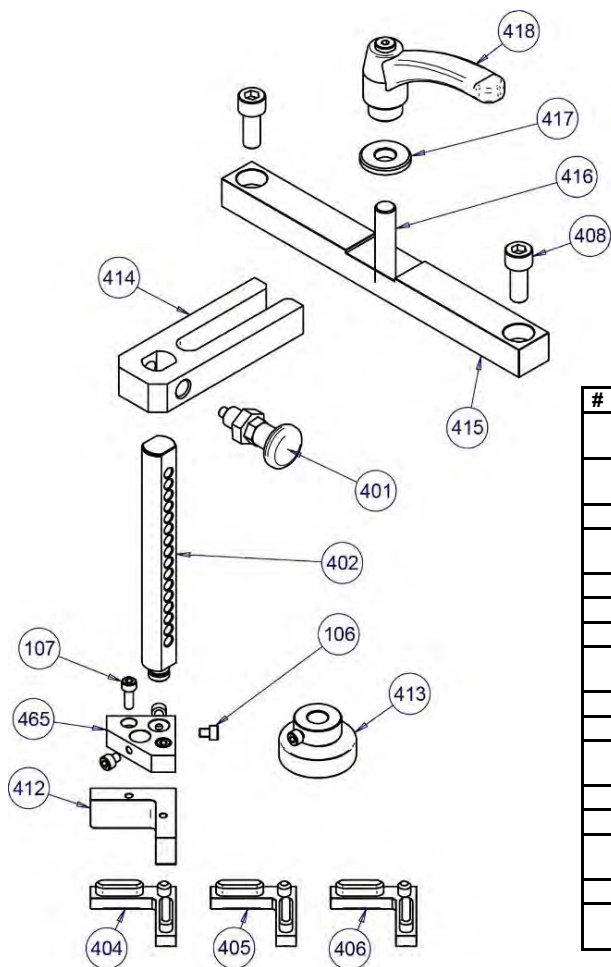

#	Object	Title	Q.ty
106	710100040	HEX SOCKET SCREW M5x6 UNI 5931 8.8 Z.B.	3
107	710100044	HEX SOCKET SCREW M5x14 UNI 5931 8.8 Z.B.	2
401	753320010	KNOB WITH SPRING PUSHER	1
402	334000100	VERTICAL STOPPER HOLDER LOCK ROD	1
404	397100001	PAD L-SHAPED 90 SHORE- BLACK	1
405	397100002	PAD L-SHAPED 75 SHORE- YELLOW	1
406	397100003	PAD L-SHAPED 65 SHORE- BLUE	1
408	710100151	HEX SOCKET SCREW M10X25 UNI 5931 8.8 Z.B.	2
412	397100005	VULKOLLAN INSERT CORNER MOUNT	1
413	244120130	STOPPER HOLDER	1
414	383600070	SHORT VERTICAL MOULDING CLAMPING MOUNT	1
415	376400010	UPPER	1
416	336210120	UPPER GRUB SCREW	1
417	336100030	VERTICAL CLAMPING MOUNT LOCKING WASHER	1
418	244660010	UPPER HANDLE	1
465	397100004	VULKOLLAN INSERT CORNER MOUNT PLATE	1

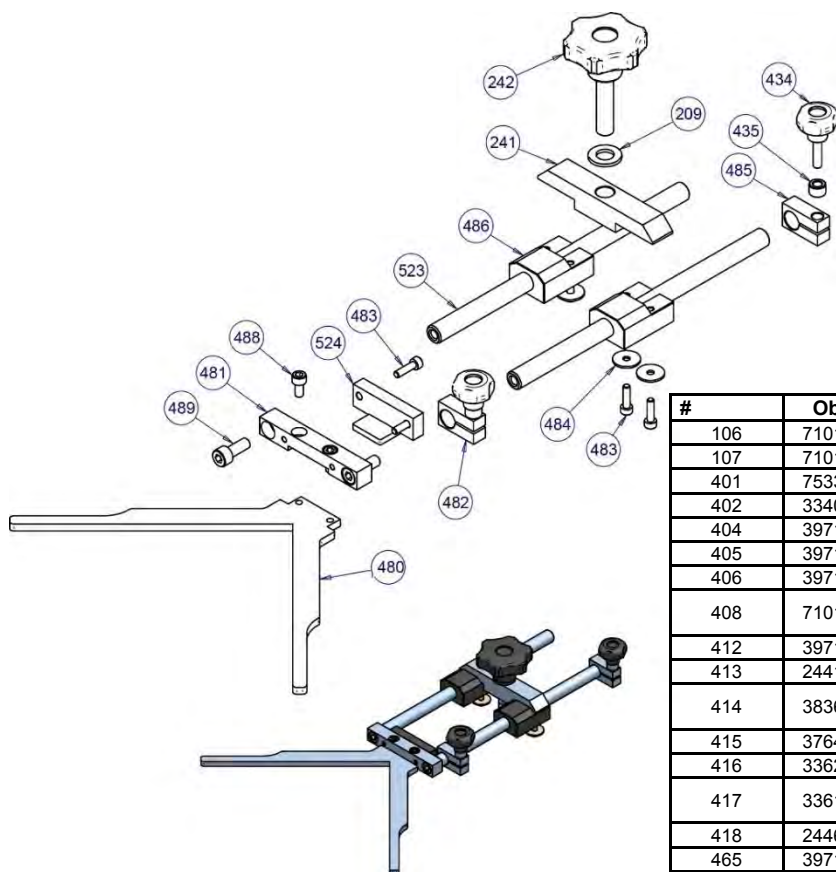

#	Object	Title	Q.ty
106	710100040	HEX SOCKET SCREW M5x6 UNI 5931 8.8 Z.B.	3
107	710100044	HEX SOCKET SCREW M5x14 UNI 5931 8.8 Z.B.	2
401	753320010	KNOB WITH SPRING PUSHER	1
402	334000100	VERTICAL STOPPER HOLDER LOCK ROD	1
404	397100001	PAD L-SHAPED 90 SHORE- BLACK	1
405	397100002	PAD L-SHAPED 75 SHORE- YELLOW	1
406	397100003	PAD L-SHAPED 65 SHORE- BLUE	1
408	710100151	HEX SOCKET SCREW M10X25 UNI 5931 8.8 Z.B.	2
412	397100005	VULKOLLAN INSERT CORNER MOUNT	1
413	244120130	STOPPER HOLDER	1
414	383600070	SHORT VERTICAL MOULDING CLAMPING MOUNT	1
415	376400010	UPPER	1
416	336210120	UPPER GRUB SCREW	1
417	336100030	VERTICAL CLAMPING MOUNT LOCKING WASHER	1
418	244660010	UPPER HANDLE	1
465	397100004	VULKOLLAN INSERT CORNER MOUNT PLATE	1
106	710100040	HEX SOCKET SCREW M5x6 UNI 5931 8.8 Z.B.	3
107	710100044	HEX SOCKET SCREW M5x14 UNI 5931 8.8 Z.B.	2

**TABLE 4 - PNEUMATIC COMPONENTS**

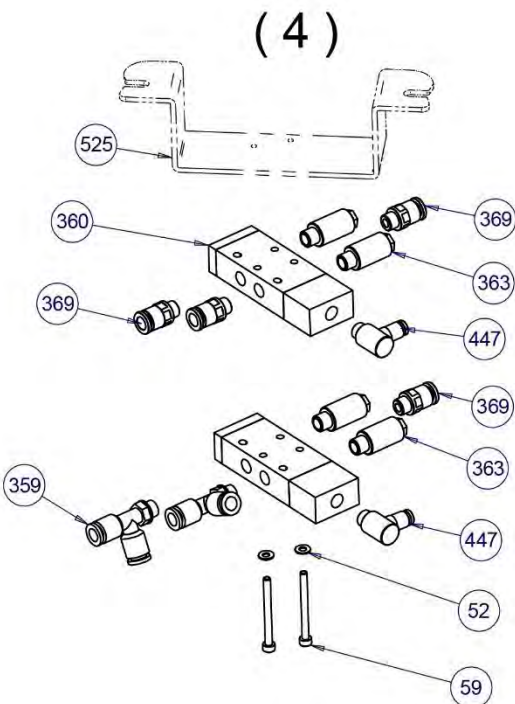
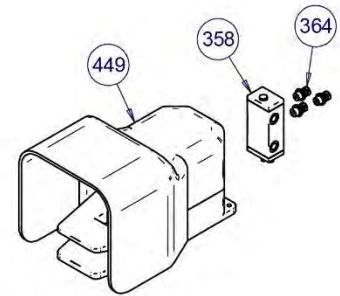
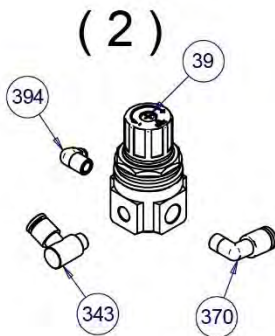
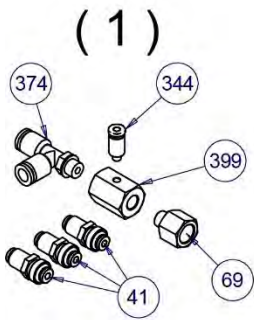
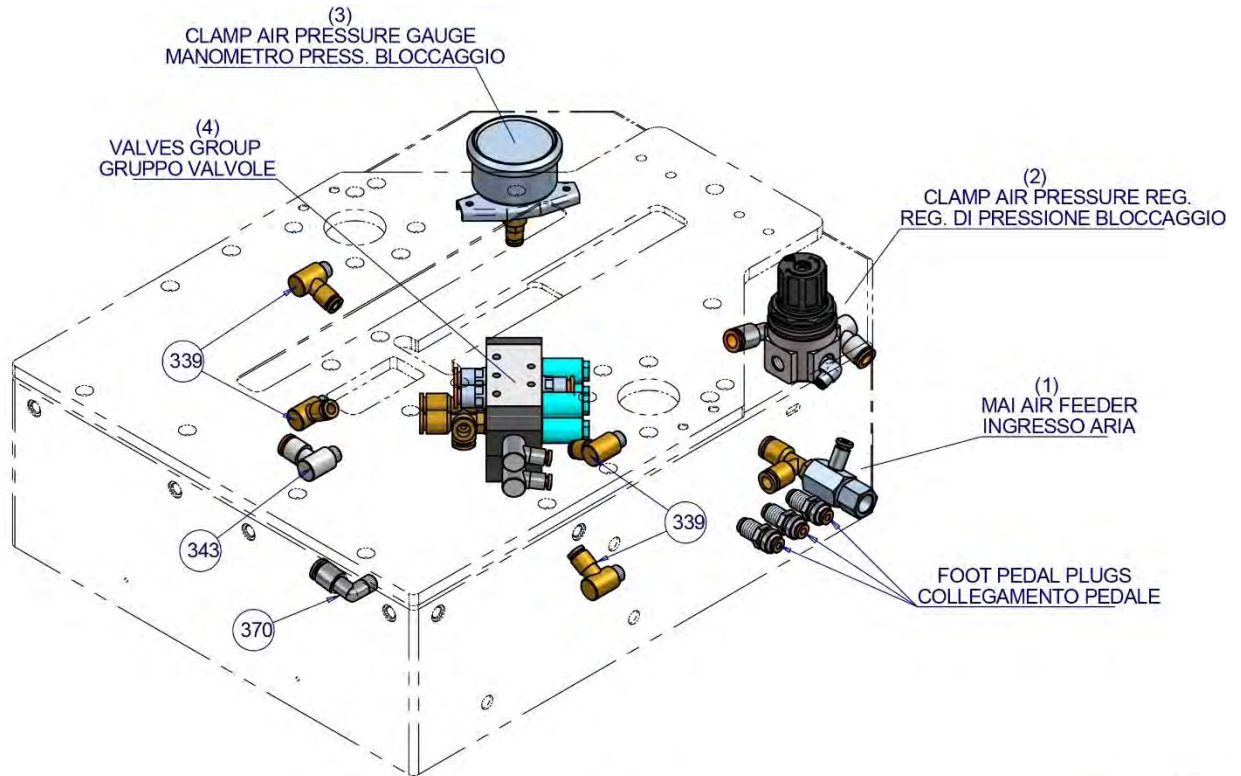

#	Object	PNEUMATIC	Q.ty
38*	734230004	PRESSURE GAUGE M3F-50 ACC 0-12 BAR 1/8	1
39*	735630002	PRESSURE REGULATOR SMC EAR111 -F01 1/8-1/4 0-8	1
41*	730090033	COMPLETE FEEDTHROUGH FITTING M11x1 TUBO 4	3
52*	718100001	WASHER M4 UNI 6592 9x4 Z.B.	2
59*	710100013	HEX SOCKET SCREW M4X45 UNI 5931 8.8	2
69*	730510001	STANDARD MF EXTENSION COUPLER MF A5 1/8 1/4 2105002	1
339	730410004	FITTING R15 6 1/8	4
343	730410002	ROT.SING.ANG. ROD QUICK COUPLER R15 8 1/8	2
344*	730090008	COUPLER RL1 M5 PIPE 4	1
359*	730360006	ROTARY COUPLER RL38 1/8 8	2
360*	732440001	VALVE T228.52.11.1 SPRING 1/8 5-WAY	2
363*	756700003	SILENCER 1/8	4
369*	730090003	STRAIGHT AUTO COUPLER R1 8 1/8 TUBE 8	4
370	730160006	QUICK-FIT CORNER COUPLER R39 8 1/8	2
374*	730360003	ROTARY COUPLER RL38 1/8 8	1
394*	730160004	FIXED QUICK-FIT COUPLER L 1/8 TUBE 4 TEF	1
397*	730090005	AIR COUPLER R2 4 1 1/8	1
399*	367010040	COUPLER MF. 1/8-1/8 HOLE M5 GALVANISED	1
447*	730410003	ROTARY COUPLER R15 4 1/8	2
449*	258710010	3-WAY PNEUMATIC PEDAL - COMPLETE ASSY	1
525*	A30100034	VALVE MOUNT	1

#	Object	3 WAY PEDAL VALVE	Q.ty
106	710100040	HEX SOCKET SCREW M5x6 UNI 5931 8.8 Z.B.	3
107	710100044	HEX SOCKET SCREW M5x14 UNI 5931 8.8 Z.B.	2

**TABLE 5 – CE PROTECTIVE EQUIPMENT**

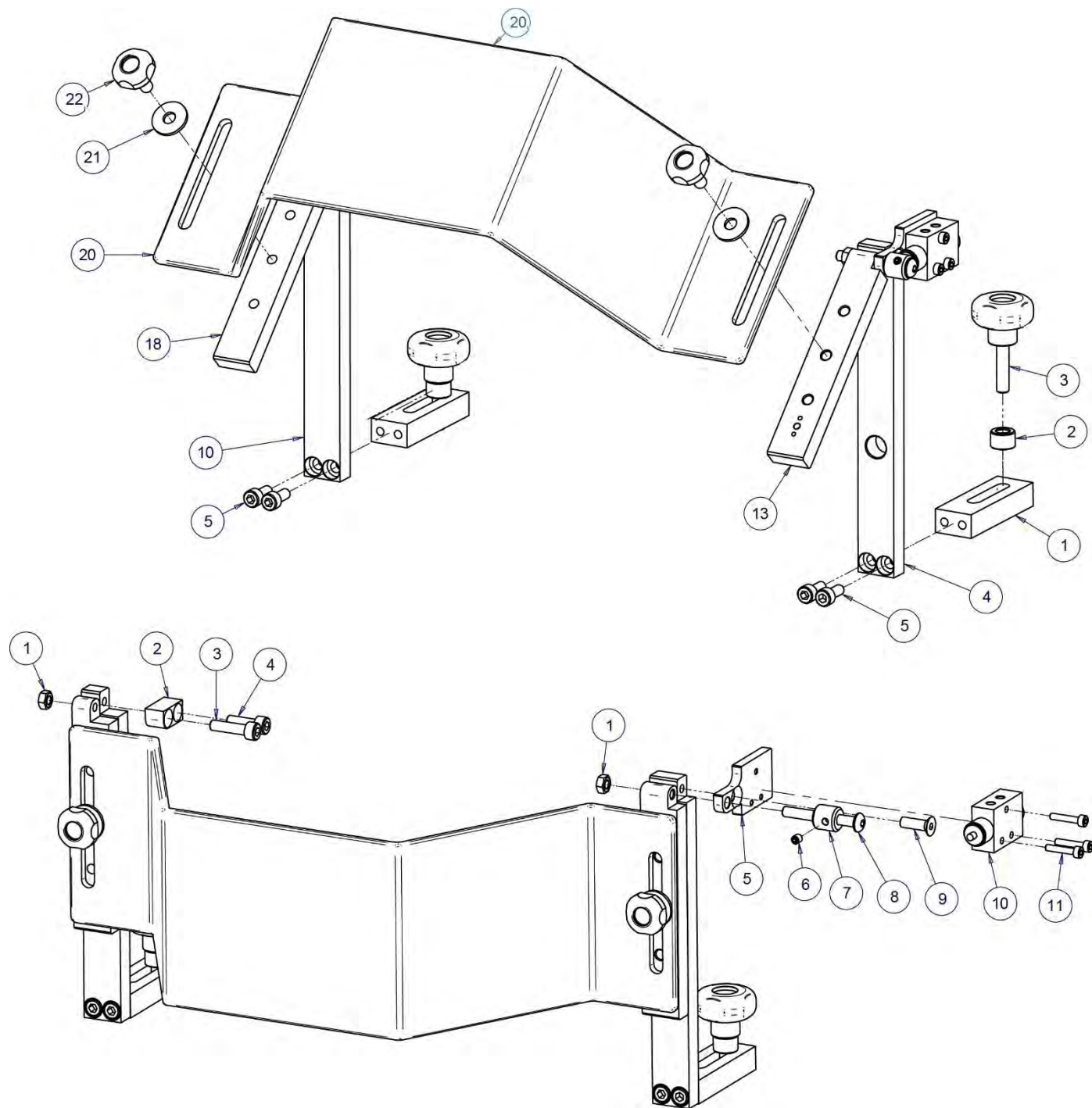

#	Object	Title	Q.ty
1	388200100	SLIDING GUARD MOUNT CE U200P	2
2	336100020	SPACER 6.5 12 L8	2
3	753320004	MALE KNOB M6x25	2
4	381300170	RH GUARD FIXED MOUNT CE	1
5	710100043	HEX SOCKET SCREW M5X12 UNI 5931 8.8 Z.B.	4
6	388200020	GUARD VALVE MOUNT CE	1
7	710200055	COUNTERSUNK HEX SOCKET SCREW 5X16 UNI 5933 10.9 Z.B.	1
8	732540003	MICRO-VALVE 0ALF106.A	1
9	710100203	HEX SOCKET SCREW M3X16 UNI 5931 Z.B.	3
10	381300200	LH GUARD FIXED MOUNT CE	1
11	388200030	GUARD BRACKET LOCK CE	1
107	710100044	HEX SOCKET SCREW M5x14 UNI 5931 8.8 Z.B.	2

#	Object	Title	Q.ty
12	710100045	HEX SOCKET SCREW M5X16 UNI 5931 8.8 Z.B.	1
13	381300180	RH GUARD FLOATING MOUNT CE	1
14	394650020	GUARD CAM	1
15	710240013	DOME HEAD HEX SOCKET SCREW M5x40 ZB	1
16	714300005	HEX SOCKET GRUB SCREW 4x5 UNI 5927 14.9 POINTED	1
17	715650002	MEDIUM NUT M5 UNI 5588 6S P.G.Z.B.	2
18	381300190	LH GUARD MOUNT CE	1
19	710100047	HEX SOCKET SCREW M5x20 UNI 5931 8.8 Z.B.	1
20	398950060	GUARD CE U200P	1
21	718100015	PLAIN WASHER M6 UNI 6593 6x18 Z.B.	2
22	753320009	HANDWHEEL D20 M6x10 ZN	2

**TABLE 6 – STAND (OPTIONAL)**

ACCESSORIO OPZIONALE  
OPTIONAL ACCESSORY

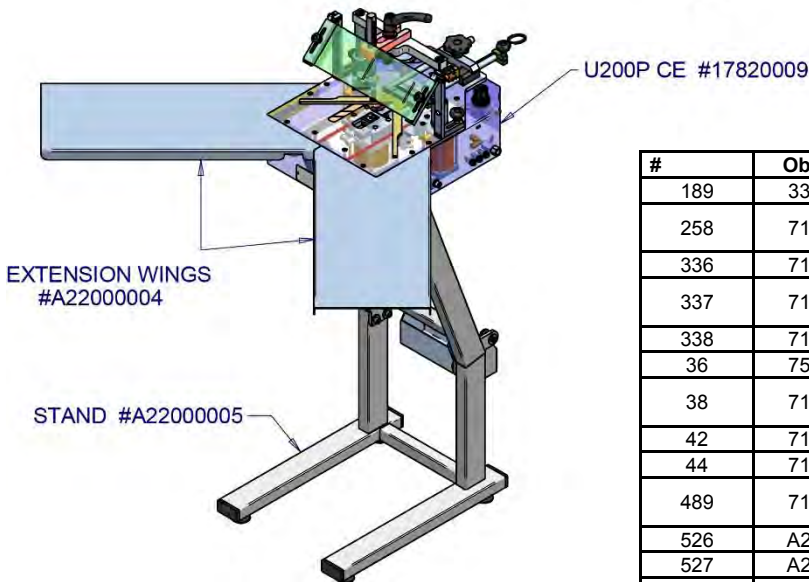
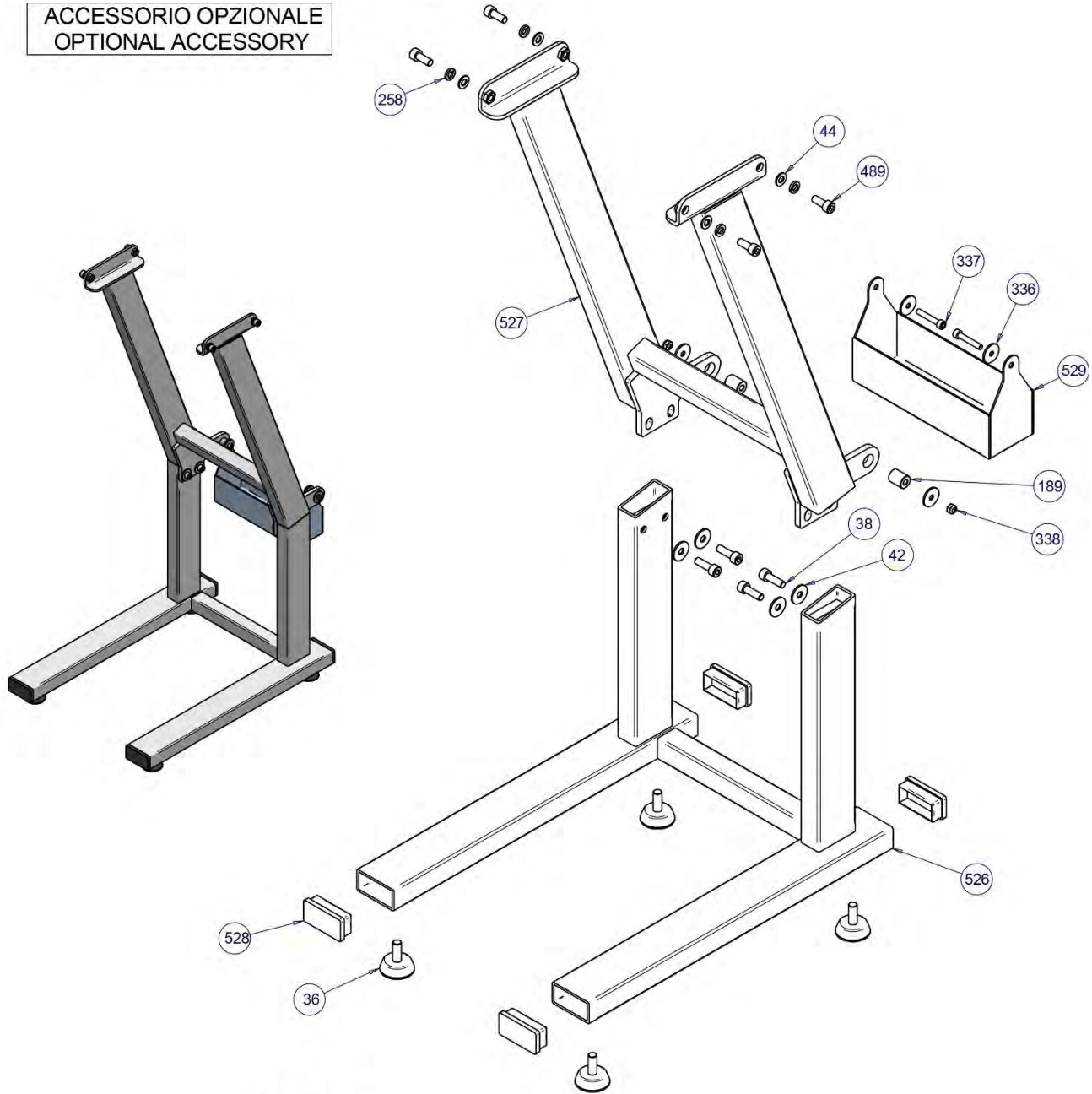

#	Object	Title	Q.ty
189	337500650	SPACER D16 L.20 MOTOR MC	2
258	718450005	GROWER WASHER M8 REINFORCED ZB	4
336	718250003	PLAIN WASHER 6X24 UNI 6593 Z.B.	4
337	710100081	HEX SOCKET SCREW M6X35 UNI 5931 8.8 Z.B.	2
338	715650008	LOW PROFILE LOCKING NUT M6 Z.B.	2
36	753690010	FOOT D.40 M10x25	4
38	710100115	HEX SOCKET SCREW M8x25 UNI 5931 8.8 Z.B.	4
42	718100016	WASHER P.L. MB x24 Z.B.	4
44	718100004	PLAIN WASHER M8x17 ZB	4
489	710100139	HEX SOCKET SCREW M8X20 UNI 5931 8.8 Z.B.	4
526	A29000001	LOWER STAND A2M 200	1
527	A29000002	UPPER STAND A2M 200	1
528	810380436	PLASTIC CAP BLACK 60x30	4
529	A30100035	ACCESSORIES HOLDER	1
189	337500650	SPACER D16 L.20 MOTOR MC	2

TABLE 7 - PNEUMATIC CIRCUIT DIAGRAM

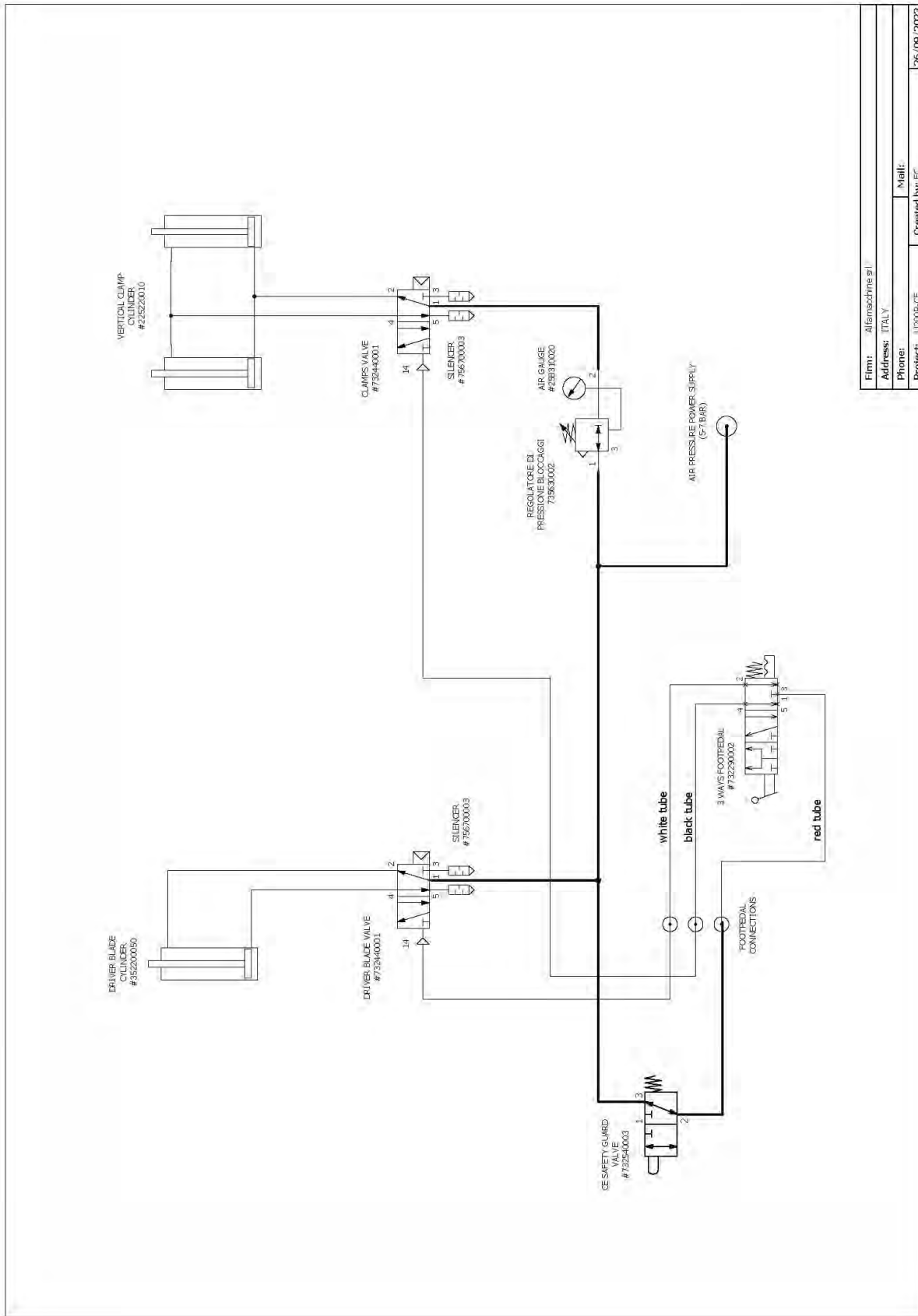

Firm:	Alfasud s.p.a.
Address:	ITALY
Phone:	
Project:	U200P-CE
Created by:	FC
	26/09/2023







**ALFAMACCHINE S.r.l.**

Via Curie Marie e Pierre, 3 - 47122 Forlì - FC  
Tel. +39-0543/783301 Fax +39-0543/783302  
<http://www.alfamacchine.com>